



US 20150115256A1

(19) **United States**

(12) **Patent Application Publication**  
**YOU**

(10) **Pub. No.: US 2015/0115256 A1**

(43) **Pub. Date: Apr. 30, 2015**

(54) **ORGANIC LIGHT-EMITTING DIODE (OLED) DISPLAY**

(52) **U.S. Cl.**

CPC ..... **H01L 27/3265** (2013.01); **H01L 27/3246** (2013.01); **H01L 51/5215** (2013.01); **H01L 51/5221** (2013.01); **H01L 51/5271** (2013.01); **H01L 29/45** (2013.01); **H01L 27/3262** (2013.01); **H01L 28/60** (2013.01)

(71) Applicant: **Samsung Display Co., Ltd.**,  
Yongin-City (KR)

(72) Inventor: **Chun-Gi YOU**, Yongin-City (KR)

(21) Appl. No.: **14/525,009**

(22) Filed: **Oct. 27, 2014**

(30) **Foreign Application Priority Data**

Oct. 30, 2013 (KR) ..... 10-2013-0130450

**Publication Classification**

(51) **Int. Cl.**

**H01L 27/32** (2006.01)  
**H01L 29/45** (2006.01)  
**H01L 49/02** (2006.01)  
**H01L 51/52** (2006.01)

(57) **ABSTRACT**

An organic light-emitting diode (OLED) display is disclosed. In one aspect, the OLED display includes a thin film transistor comprising an active layer, a gate electrode, a source electrode, and a drain electrode. A first insulating layer is formed at least between the active layer and the gate electrode and a second insulating layer formed at least between the gate, source, and drain electrodes. The OLED display also includes a third insulating layer covering the source and drain electrodes and a pixel electrode including a first portion formed in first and second openings respectively defined in the second and third insulating layers and a second portion formed outside of the second opening. A pixel defining layer is formed over the second portion of the pixel electrode and the third insulating layer and has a third opening. The third opening has an area greater than that of the second opening.

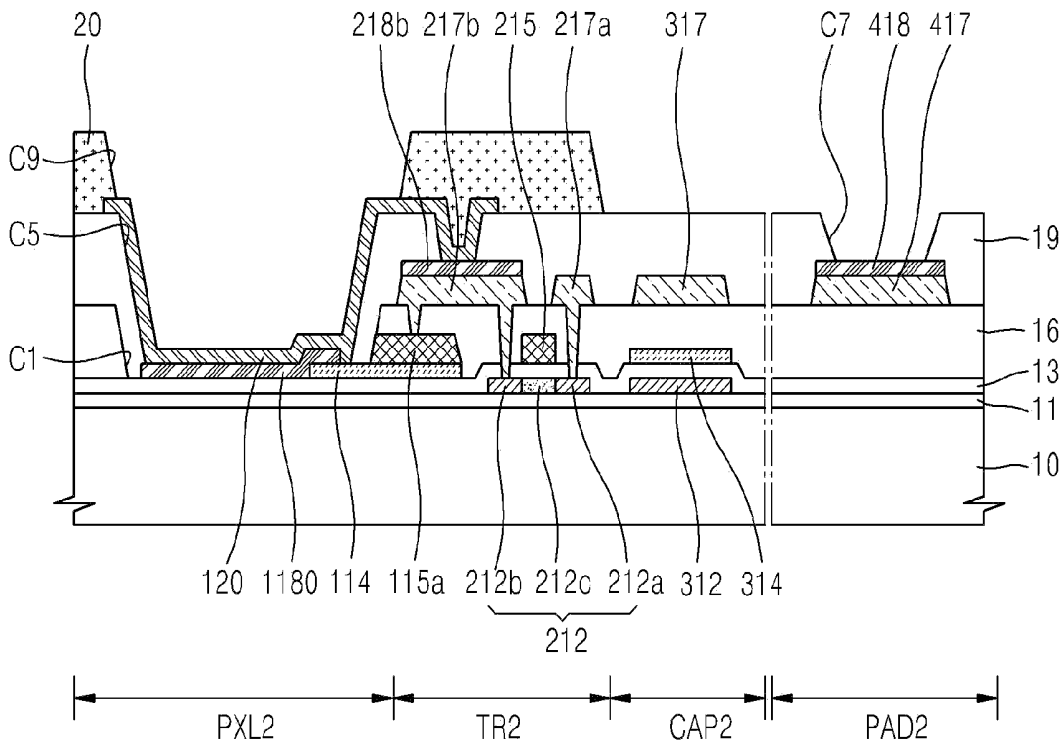

FIG. 1

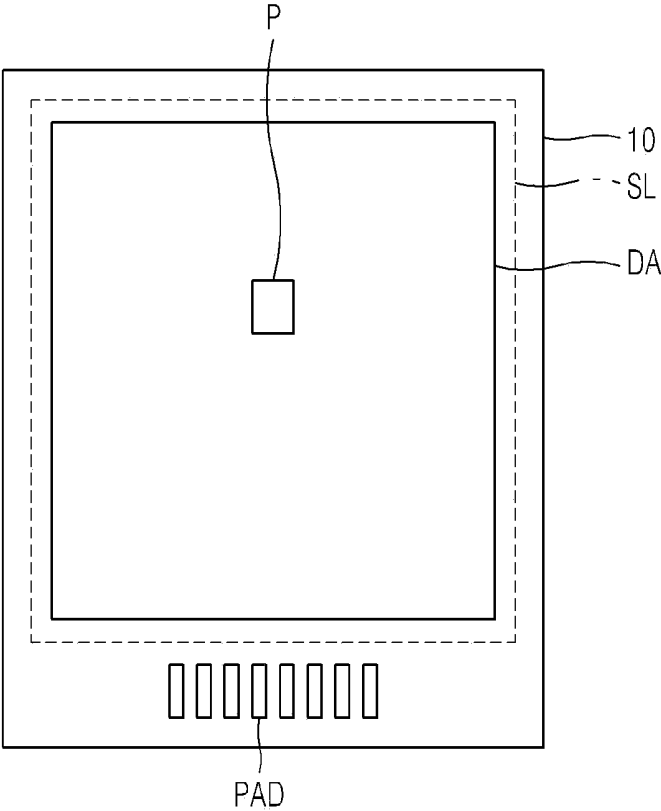

FIG. 2

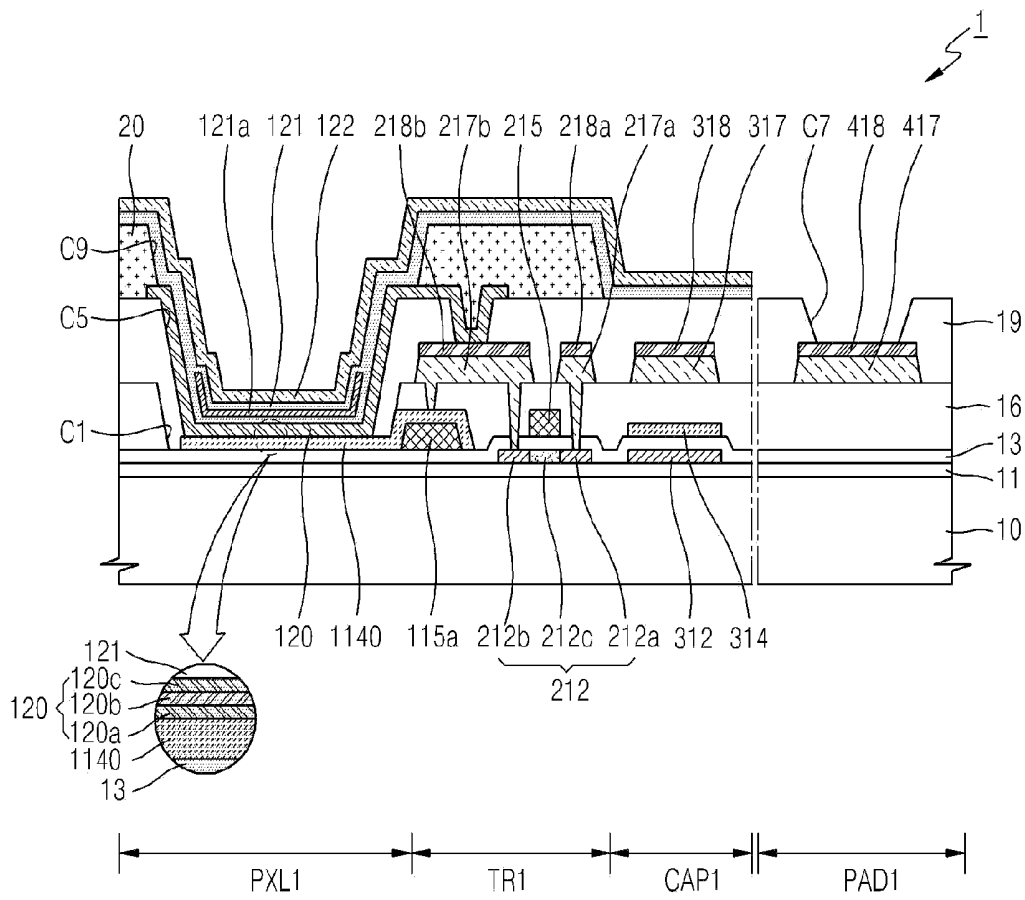

FIG. 3

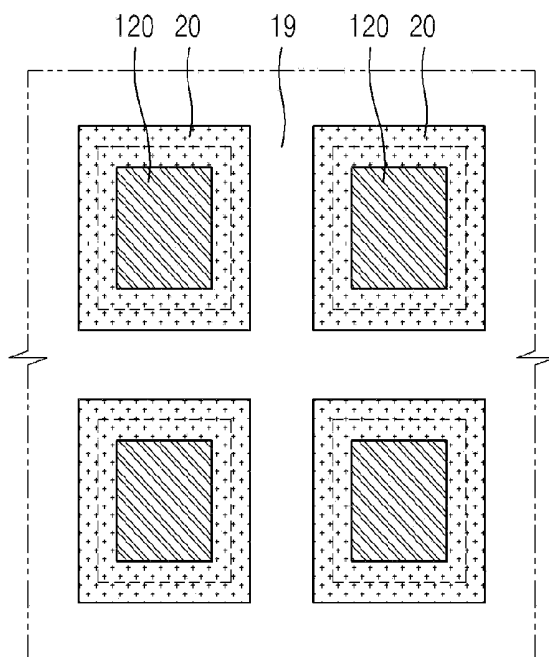

FIG. 4

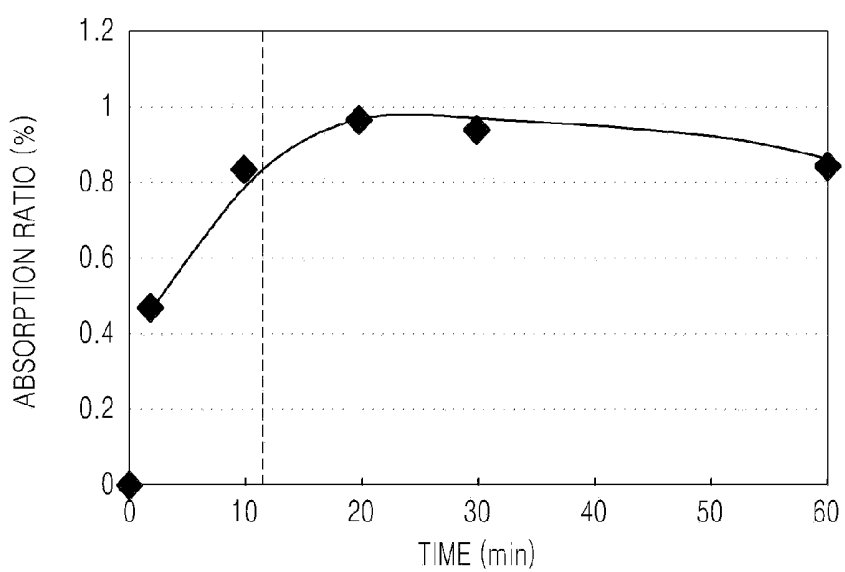

FIG. 5

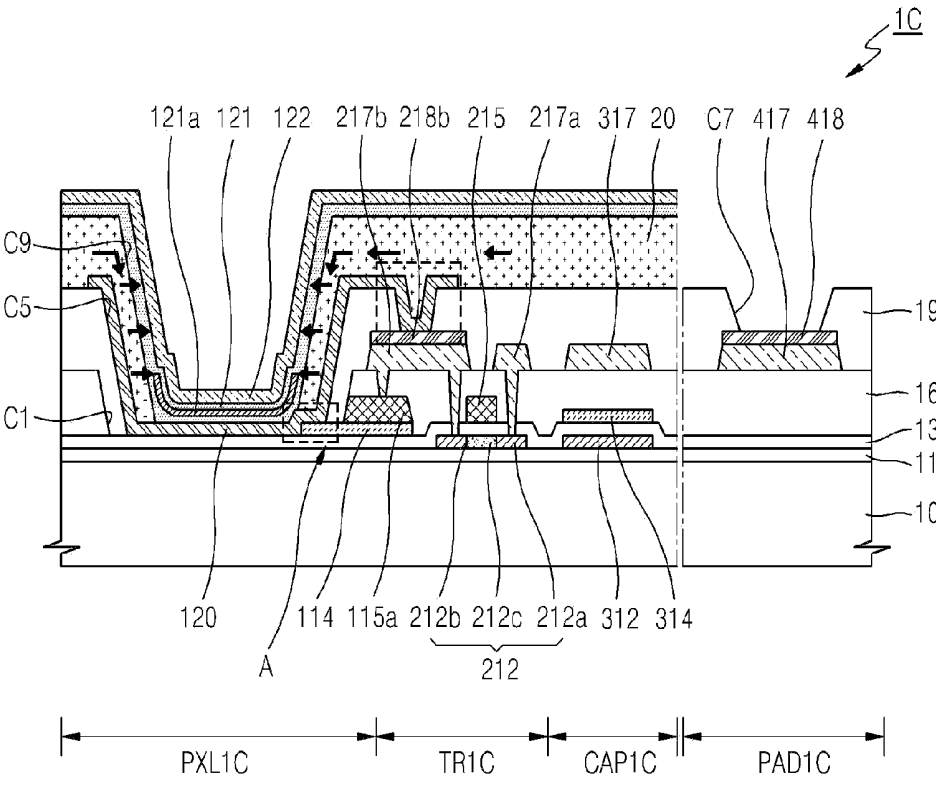

FIG. 6

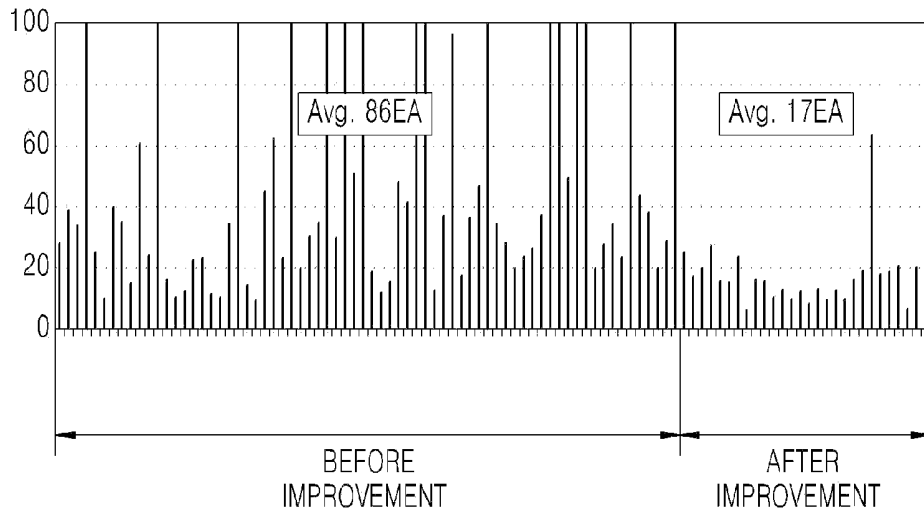

FIG. 7

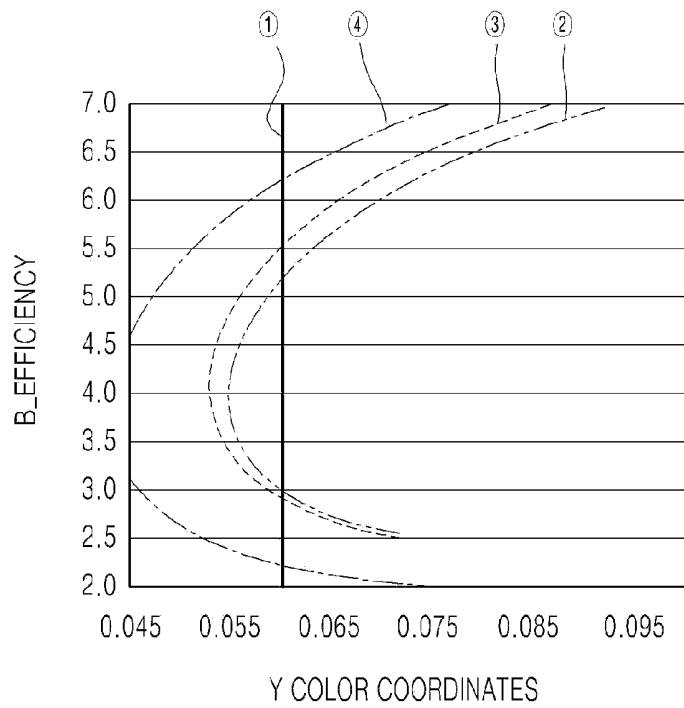

FIG. 8A

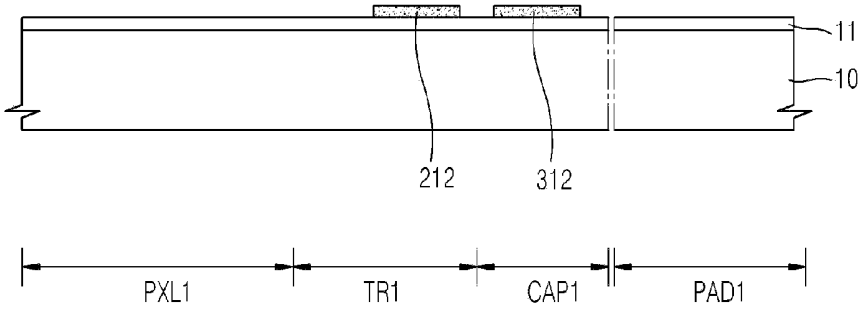

FIG. 8B

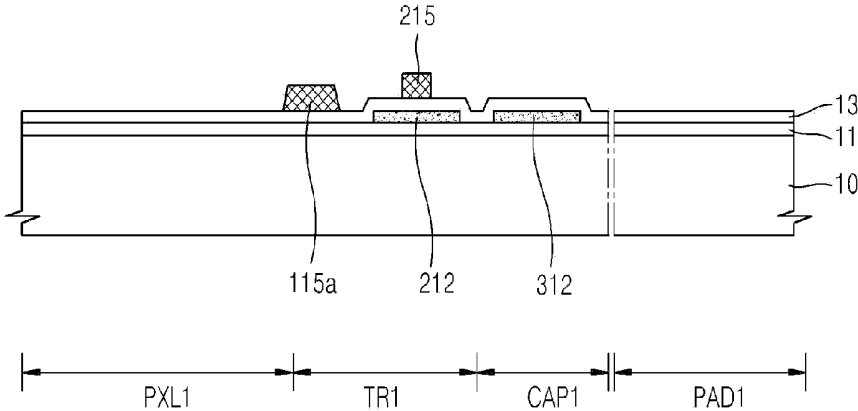

FIG. 8C

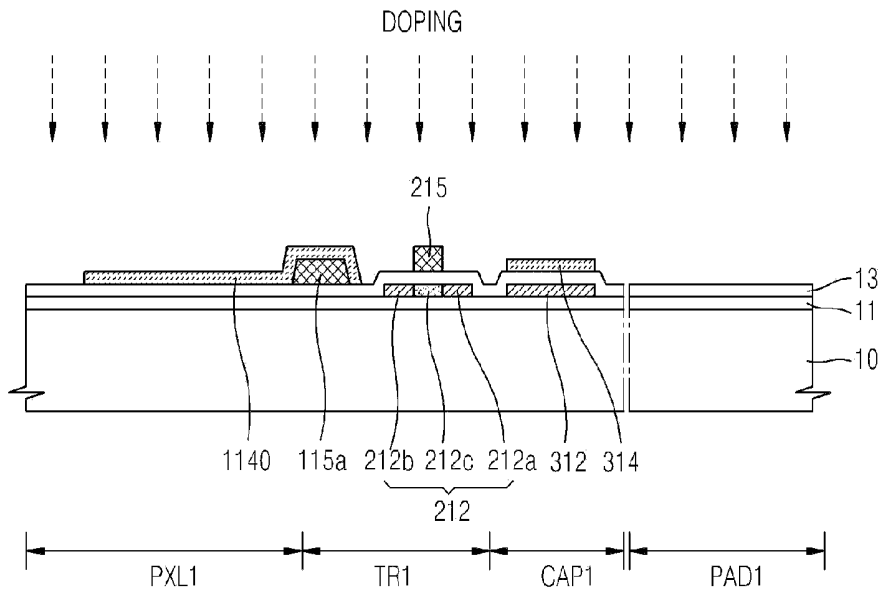

FIG. 8D

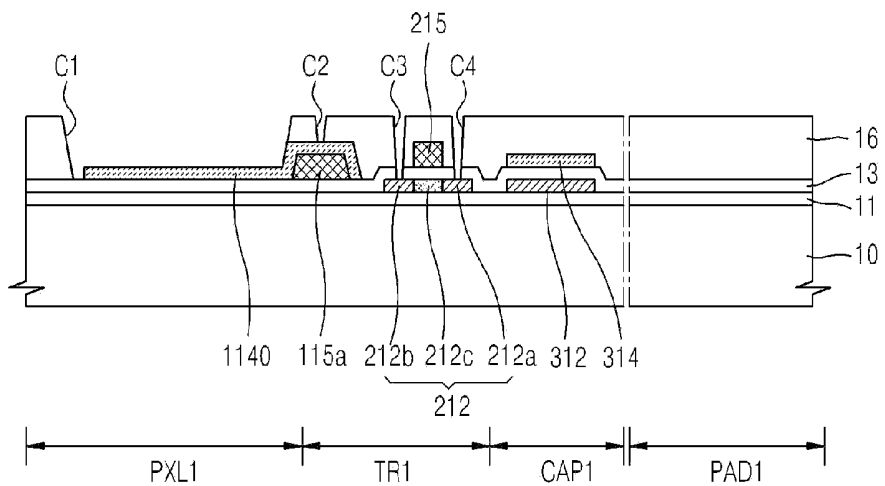

FIG. 8E

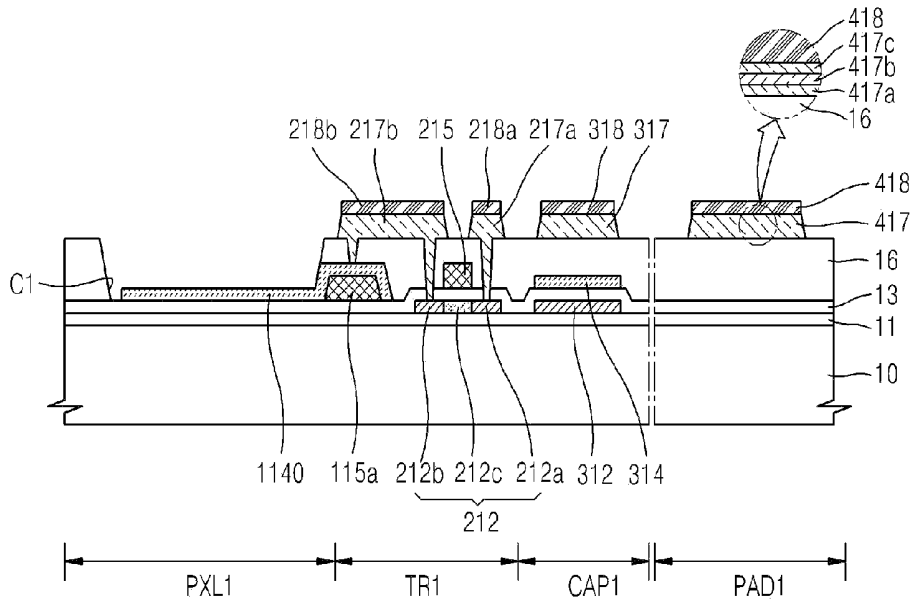

FIG. 8F

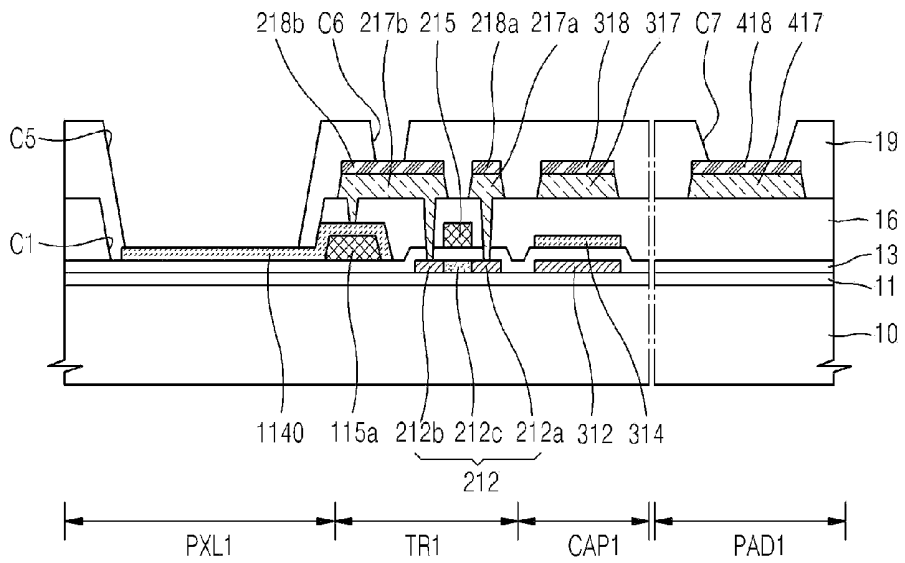

FIG. 8G

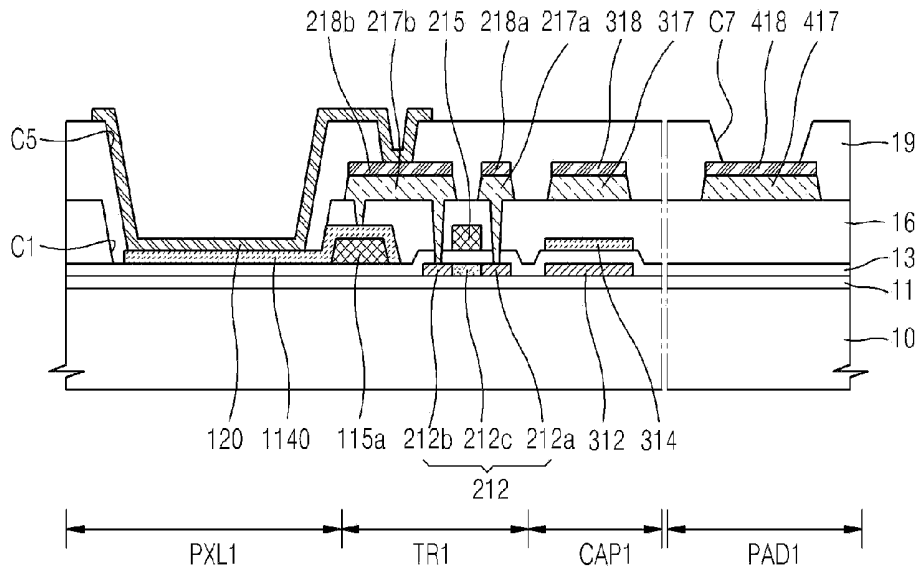

FIG. 8H

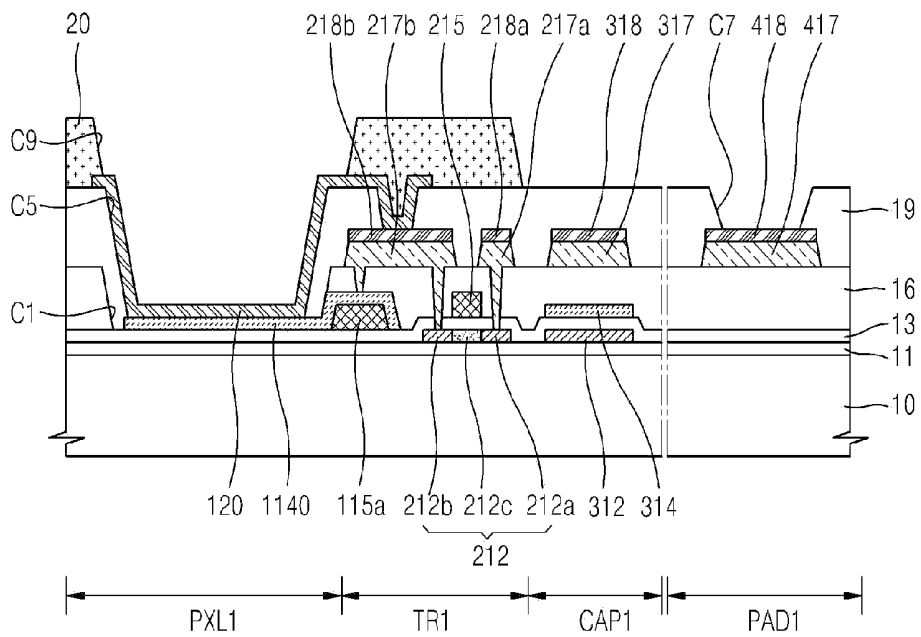

FIG. 9

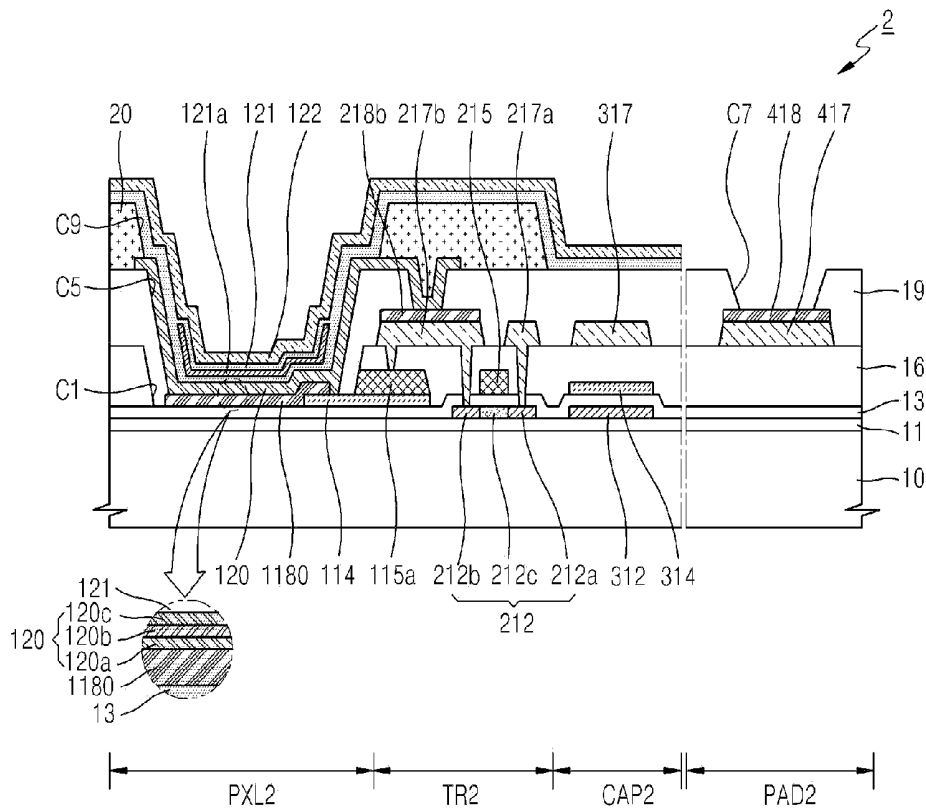

FIG. 10A

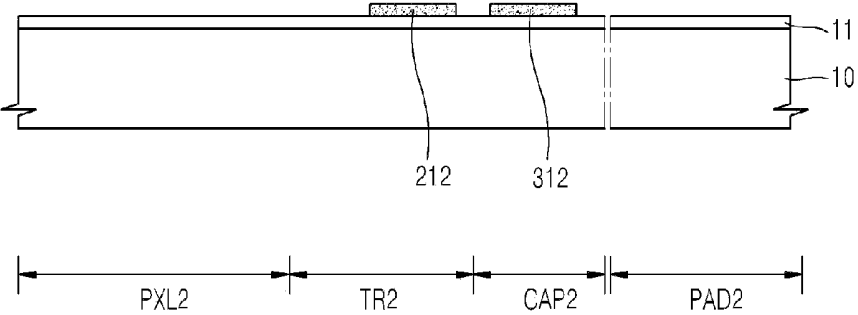

FIG. 10B

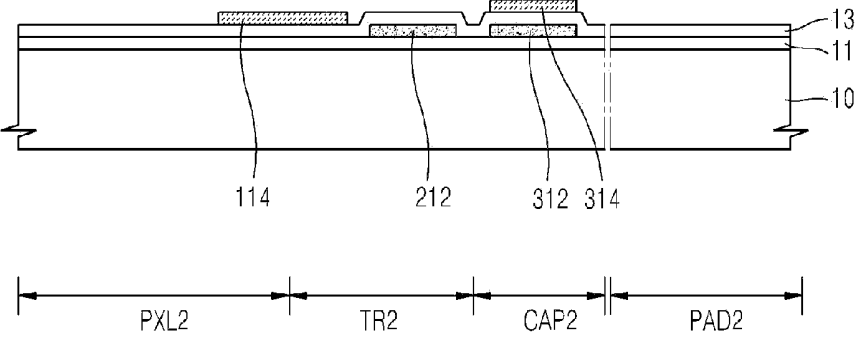

FIG. 10C

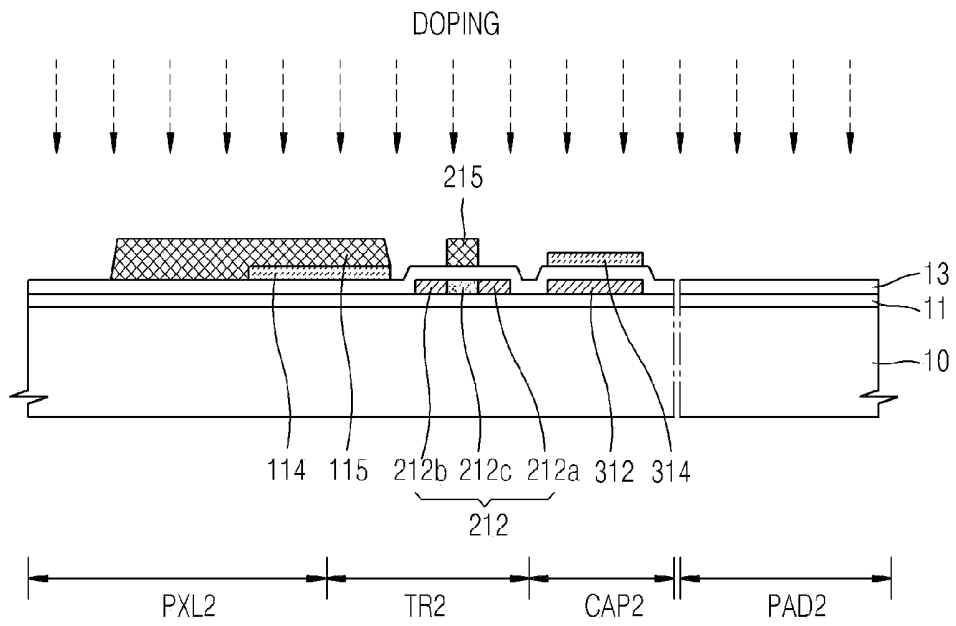

FIG. 10D

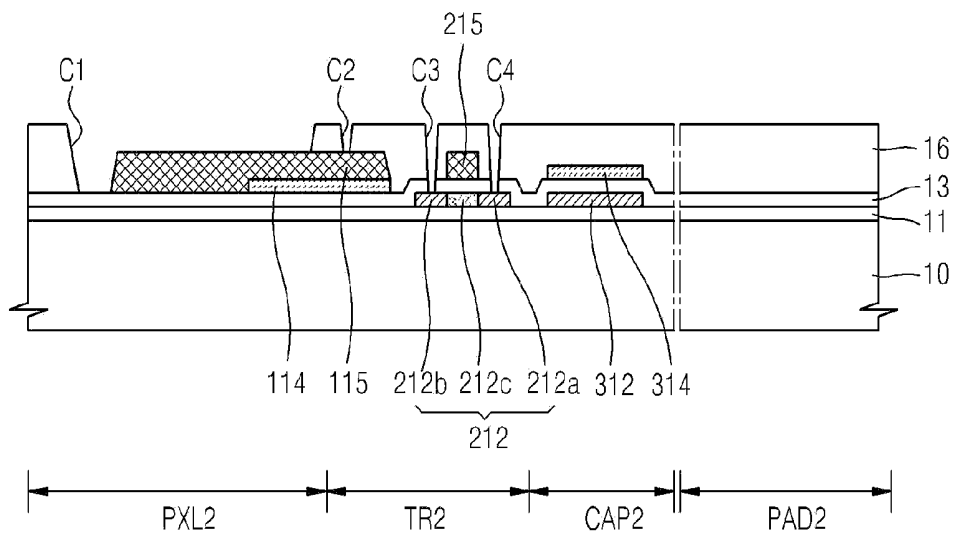

FIG. 10E

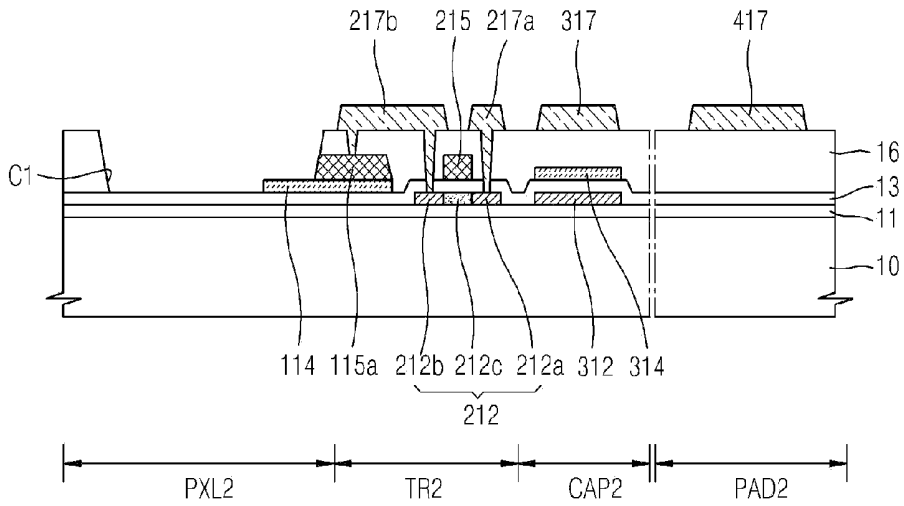

FIG. 10F

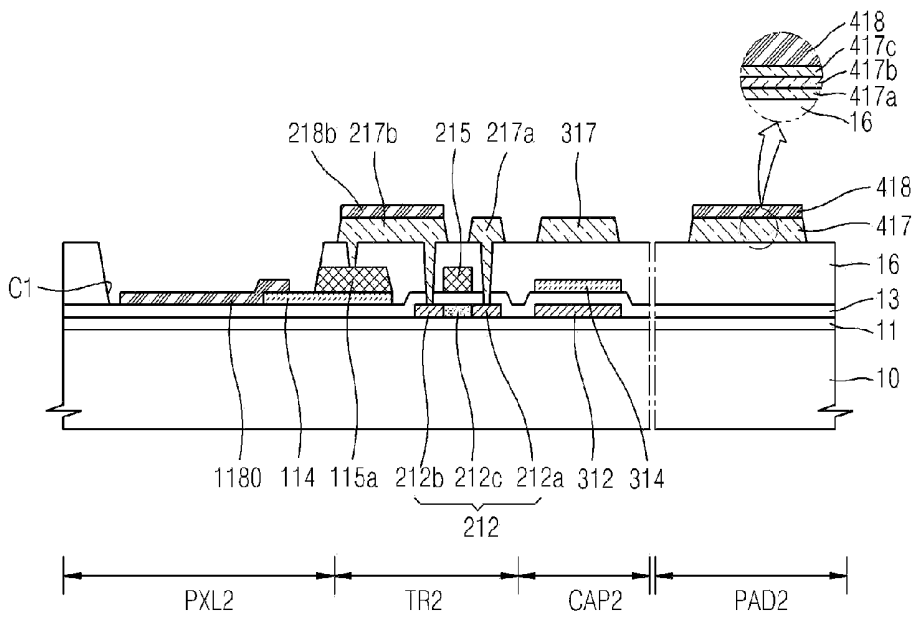

FIG. 10G

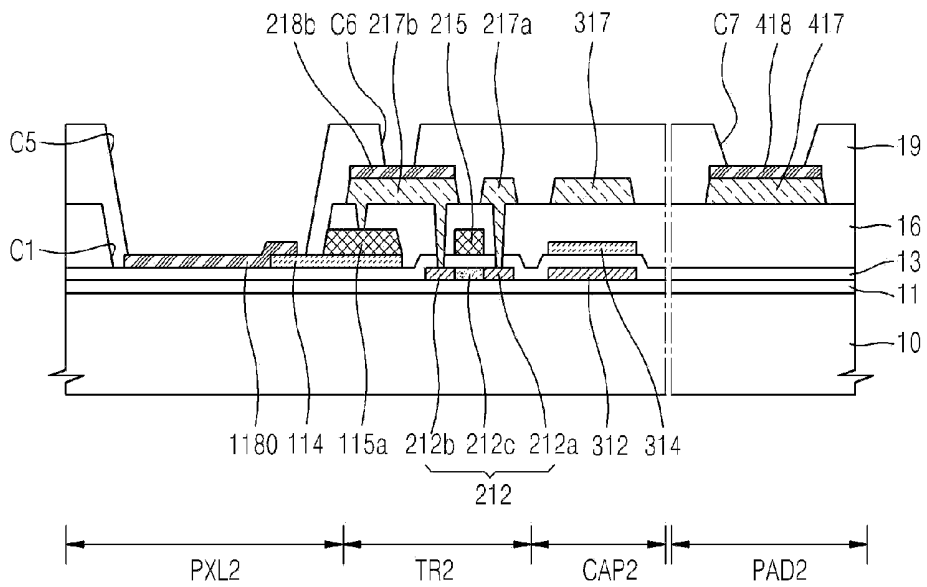

FIG. 10H

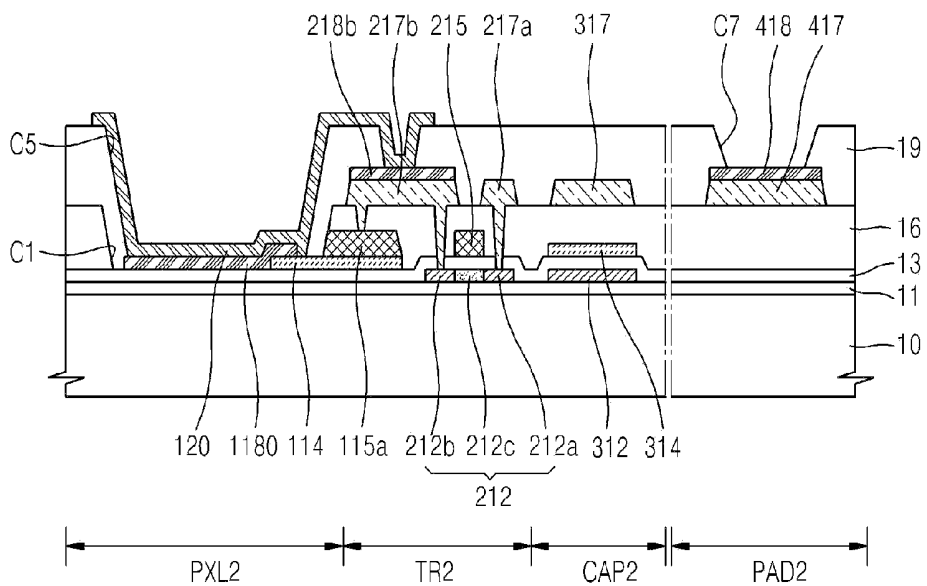
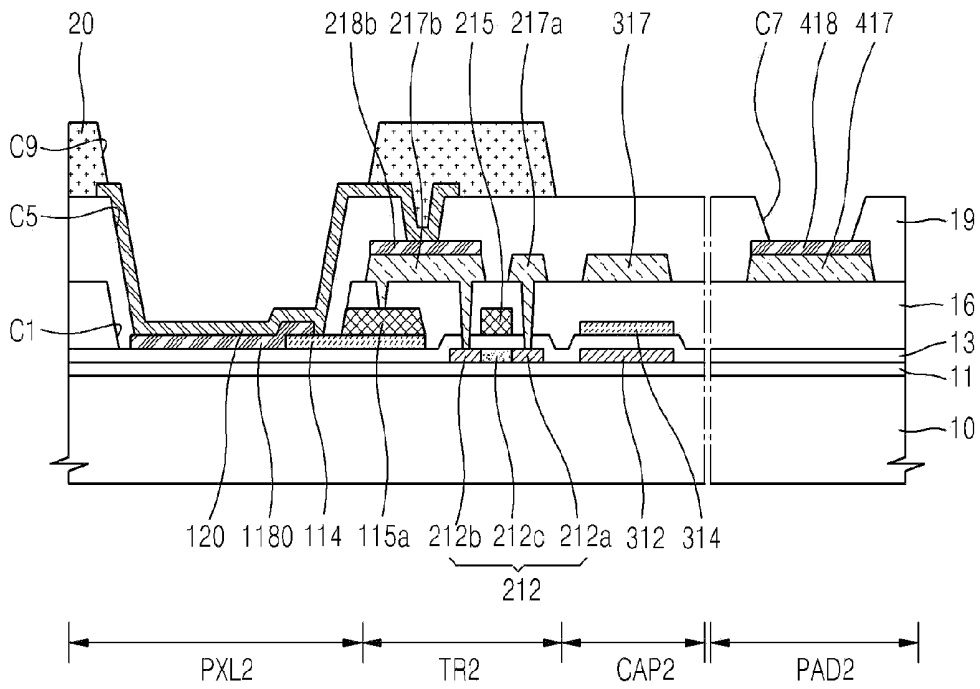

FIG. 10I



**ORGANIC LIGHT-EMITTING DIODE (OLED)  
DISPLAY****CROSS-REFERENCE TO RELATED  
APPLICATIONS**

**[0001]** This application claims the benefit of Korean Patent Application No. 10-2013-0130450, filed on Oct. 30, 2013, in the Korean Intellectual Property Office, the disclosure of which is incorporated herein in its entirety by reference.

**BACKGROUND**

**[0002]** 1. Field

**[0003]** The described technology generally relates to an organic light-emitting diode (OLED) display.

**[0004]** 2. Description of the Related Technology

**[0005]** OLED displays include a hole injection electrode, an electron injection electrode, and an organic emitting layer formed therebetween. OLED displays are self-emissive and emit light when holes injected from the hole injection electrode and electrons injected from the electron injection electrode recombine and decay in the organic emitting layer. OLED displays have favorable characteristics such as low power consumption, high luminance, and fast response speeds, and are thus regarded as next-generation displays.

**SUMMARY OF CERTAIN INVENTIVE ASPECTS**

**[0006]** One inventive aspect is an organic light-emitting diode (OLED) display having a high light efficiency, a high yield, and an improved display quality.

**[0007]** Another aspect is an OLED display including a thin film transistor including an active layer, a gate electrode, and a source electrode and a drain electrode, a first insulating layer disposed between the active layer and the gate electrode, a second insulating layer disposed between the gate electrode and the source and drain electrodes, a third insulating layer covering the source and drain electrodes, a pixel electrode disposed in openings formed in the second insulating layer and the third insulating layer, wherein an end portion of the pixel electrode is disposed outside the opening formed in the third insulating layer, a fourth insulating layer having a third opening, wherein a portion of fourth insulating layer that covers the end portion of the pixel electrode is disposed outside the opening formed in the third insulating layer, an intermediate layer that is disposed on the pixel electrode and includes an organic emitting layer, and an opposite electrode disposed on the intermediate layer, wherein the third opening has an area greater than that of the second opening.

**[0008]** The third insulating layer may be an organic insulating layer.

**[0009]** The fourth insulating layer may be an organic insulating layer.

**[0010]** The fourth insulating layer may cover the end portion of the pixel electrode in the form of a closed loop.

**[0011]** The pixel electrode may include a semi-transmissive metal layer and the opposite electrode may include a reflection layer.

**[0012]** The semi-transmissive metal layer may include silver (Ag) or an Ag alloy.

**[0013]** The OLED display may further include a first transparent conductive oxide layer between the semi-transmissive metal layer and the substrate.

**[0014]** The OLED display may further include a second transparent conductive oxide layer between the semi-transmissive metal layer and the intermediate layer.

**[0015]** The OLED display may further include a light characteristics adjusting layer between the first insulating layer and the pixel electrode.

**[0016]** The light characteristics adjusting layer may have a thickness of about 200 Å to about 800 Å.

**[0017]** The light characteristics adjusting layer may include a transparent conductive oxide.

**[0018]** An end portion of the pixel electrode may be electrically connected to one of the source and drain electrodes via a contact hole formed in the third insulating layer.

**[0019]** The pixel electrode disposed in the opening formed in the third insulating layer may contact a contact layer disposed between the first insulating layer and the second insulating layer and the contact layer may be electrically connected to one of the source and drain electrodes through a contact hole formed in the second insulating layer.

**[0020]** The source electrode and the drain electrode may be formed of a plurality of heterogeneous metal layers having different electron mobilities.

**[0021]** The source electrode and the drain electrode may include a layer including molybdenum (Mo) and a layer including aluminum (Al).

**[0022]** The OLED display may further include a wiring protection layer on the source and drain electrodes.

**[0023]** Etching surfaces of the source and drain electrodes and the wiring protection layer may be the same.

**[0024]** The OLED display may further include a capacitor including a first electrode formed in the same layer as the active layer and a second electrode disposed in the same layer as the gate electrode.

**[0025]** The first electrode of the capacitor may include a semiconductor material doped with ion impurities.

**[0026]** The second electrode of the capacitor may include a transparent conductive oxide.

**[0027]** The second electrode of the capacitor may be formed of the same material as the light characteristics adjusting layer disposed between the first insulating layer and the pixel electrode.

**[0028]** The OLED display may further include a first pad layer formed of the same material as the source and drain electrodes and a second pad layer disposed on the first pad layer.

**[0029]** The second pad layer may be formed of the same material as the light characteristics adjusting layer disposed between the first insulating layer and the pixel electrode.

**[0030]** An opening formed in the second insulating layer, an opening formed in the third insulating layer, and an opening formed in the fourth insulating layer may overlap one another.

**[0031]** An opening formed in the fourth insulating layer may be greater than an opening formed in the third insulating layer.

**[0032]** Another aspect is an OLED display including a substrate, an insulating layer formed over the substrate and defining a plurality of openings, a plurality of pixels formed over the substrate and respectively corresponding to the openings, each of the pixels including a pixel electrode including a first portion formed in the corresponding opening and a second portion formed over the insulating layer and not forming in the opening, and a pixel defining layer formed over the second portion of the pixel electrode and the insulating layer, wherein

each of the pixel defining layers has a closed loop shape, and wherein each of the pixel defining layers is spaced apart from adjacent pixel defining layers.

[0033] Each of the pixel defining layers is not formed in the corresponding opening. The length of the first portion of the pixel electrode is greater than that of the second portion of the pixel electrode. The second portion comprises a peripheral portion of the pixel electrode.

#### BRIEF DESCRIPTION OF THE DRAWINGS

[0034] FIG. 1 is a schematic plan view illustrating an OLED display according to an embodiment.

[0035] FIG. 2 is a schematic cross-sectional view illustrating portions of a pixel and a pad unit of an OLED display according to an embodiment.

[0036] FIG. 3 is a schematic plan view illustrating the arrangement relationship between a pixel electrode and a fourth insulating layer in a plurality of pixels of an OLED display according to an embodiment.

[0037] FIG. 4 is a graph showing the relationship between a standby exposure time and an absorption ratio of a fourth insulating layer.

[0038] FIG. 5 is a schematic cross-sectional view illustrating portions of a pixel and a pad unit of an OLED display according to a comparative example.

[0039] FIG. 6 illustrates the number of dark point defects of an OLED display under the same conditions before and after applying a transparent protection layer.

[0040] FIG. 7 is a graph showing a relationship between y color coordinates and efficiency of a blue emitting layer.

[0041] FIGS. 8A through 8H are schematic cross-sectional views illustrating a method of manufacturing an OLED display according to an embodiment.

[0042] FIG. 9 is a schematic cross-sectional view illustrating portions of a pixel and a pad unit of an OLED display according to another embodiment.

[0043] FIGS. 10A through 10I are schematic cross-sectional views illustrating a method of manufacturing an OLED display according to another embodiment.

#### DETAILED DESCRIPTION OF CERTAIN INVENTIVE EMBODIMENTS

[0044] Reference will now be made in detail to embodiments, examples of which are illustrated in the accompanying drawings, wherein like reference numerals refer to like elements throughout. In this regard, the present embodiments may have different forms and should not be construed as being limited to the descriptions set forth herein. Accordingly, the embodiments are merely described below, by referring to the figures, to explain aspects of the present description.

[0045] While the described technology is amenable to various modifications and alternative forms, specific embodiments have been shown by way of example in the drawings and are described in detail below. The effects and features of the described technology and implementation methods thereof will be clarified through the following embodiments described with reference to the accompanying drawings. The described technology may, however, be embodied in different forms and should not be construed as limited to the embodiments set forth herein.

[0046] Hereinafter, embodiments of the described technology will be described in detail with reference to the accom-

panying drawings. Like reference numerals in the drawings denote like elements, and thus, duplication of their descriptions will be omitted.

[0047] It will be understood that although the terms “first”, “second”, etc. may be used herein to describe various components, these components should not be limited by these terms. These terms are only used to distinguish one component from another.

[0048] As used herein, the singular forms “a”, “an”, and “the” are intended to include the plural forms as well, unless the context clearly indicates otherwise.

[0049] It will be further understood that the terms “comprises” and/or “comprising” used herein specify the presence of the stated features or components, but do not preclude the presence or addition of one or more other features or components.

[0050] It will be understood that when a layer, region, or component is referred to as being “formed on,” another layer, region, or component, it can be directly or indirectly formed on the other layer, region, or component. That is, for example, intervening layers, regions, or components may also be present.

[0051] The sizes of elements in the drawings may be exaggerated for convenience of explanation. In other words, since the sizes and thicknesses of the components in the drawings are illustrated only for convenience of explanation, the following embodiments are not limited thereto.

[0052] As used herein, the term “and/or” includes any and all combinations of one or more of the associated listed items. Expressions such as “at least one of,” when preceding a list of elements, modify the entire list of elements and do not modify the individual elements of the list.

[0053] FIG. 1 is a schematic plan view illustrating an OLED display 1 according to an embodiment. FIG. 2 is a schematic cross-sectional view illustrating portions of a pixel P and a pad unit PAD of the OLED display 1.

[0054] Referring to FIG. 1, a display area DA including a plurality of pixels P and displaying an image and a pad unit PAD are formed on a substrate 10 of the OLED display 1. The display area DA is formed inside a sealing line SL. Also, an encapsulation member (not shown) for encapsulating the display area DA is formed along the sealing line SL.

[0055] Referring to FIG. 2, a pixel area PXL1 including at least one organic emitting layer 121a, a transistor area TR1 including at least one thin film transistor (TFT), a capacitor area CAP1 including at least one capacitor, and a pad area PAD1 are formed on the substrate 10 of the OLED display 1.

[0056] The substrate 10 may be formed not only of glass but also of a plastic including polyethylene terephthalate (PET), polyethylene naphthalate (PEN), polyimide, or the like.

[0057] A buffer layer 11 may be further included to planarize the substrate 10 and prevent penetration of impurity elements. The buffer layer 11 may be formed as a single layer or as multiple layers including a silicon nitride and/or a silicon oxide layer.

[0058] The at least one thin film transistor includes an active layer 212, a gate electrode 215, a source electrode 217a, and a drain electrode 217b.

[0059] The active layer 212 includes a channel area 212c, a source area 212a, and a drain area 212b. The source and drain areas 212a and 212b are formed at opposing sides of the channel area 212c and are doped with ion impurities. The active layer 212 may include various materials. For example, the active layer 212 may include an inorganic semiconductor

material such as amorphous silicon or crystalline silicon. Alternatively, the active layer **212** may include an oxide semiconductor material. Alternatively, the active layer **212** may include an organic semiconductor material.

[0060] A first insulating layer **13** which is a gate insulating layer is formed on the active layer **212**, and a gate electrode **215** is formed on the first insulating layer **13** at a position corresponding to the channel area **212c**.

[0061] The gate electrode **215** may be formed of a single layer or multiple layers formed of at least one metal such as aluminum (Al), platinum (Pt), palladium (Pd), silver (Ag), magnesium (Mg), gold (Au), nickel (Ni), neodymium (Nd), iridium (Ir), chromium (Cr), nickel (Li), calcium (Ca), molybdenum (Mo), titanium (Ti), tungsten (W), or copper (Cu).

[0062] A second insulating layer **16**, which is an interlayer insulating layer, is formed on the gate electrode **215**, and a source electrode **217a** and a drain electrode **217b** are formed on the second insulating layer **16**.

[0063] The source and drain electrodes **217a** and **217b** respectively contact the source and drain areas **212a** and **212b** of the active layer **212** through an opening (not shown) formed in the second insulating layer **16**. The source and drain electrodes **217a** and **217b** may be formed of at least two stacked layers formed of heterogeneous metals having different electron mobilities. For example, the source and drain electrodes **217a** and **217b** may be formed of at least two stacked metal layers formed of at least one material such as aluminum (Al), platinum (Pt), palladium (Pd), silver (Ag), magnesium (Mg), gold (Au), nickel (Ni), neodymium (Nd), iridium (Ir), chromium (Cr), nickel (Li), calcium (Ca), molybdenum (Mo), titanium (Ti), tungsten (W), or copper (Cu).

[0064] Wiring protection layers **218a** and **218b** are respectively formed on the source and drain electrodes **217a** and **217b**. The wiring protection layers **218a** and **218b** respectively have the same etching surfaces as the source and drain electrodes **217a** and **217b**. The source and drain electrodes **217a** and **217b** are patterned during the same mask operation as the wiring protection layers **218a** and **218b**.

[0065] While not illustrated in FIG. 2, wirings such as a data wiring (not shown) and an electrode power supply wiring (not shown) that are formed of the same materials as the source and drain electrodes **217a** and **217b** may be formed in the same layer as the source and drain electrodes **217a** and **217b** and the wiring protection layers **218a** and **218b** may be formed on the data wiring (not shown) and the electrode power supply wiring (not shown).

[0066] The first insulating layer **13** and the second insulating layer **16** may be formed of an inorganic insulating layer. The first and second insulating layers **13** and **16** may be formed of a single layer or multiple layers formed of one of SiO<sub>2</sub>, SiNx, SiON, Al<sub>2</sub>O<sub>3</sub>, TiO<sub>2</sub>, Ta<sub>2</sub>O<sub>5</sub>, HfO<sub>2</sub>, ZrO<sub>2</sub>, or lead zirconate titanate (PZT).

[0067] A third insulating layer **19** is formed on the second insulating layer **16** to cover the source and drain electrodes **217a** and **217b**.

[0068] The third insulating layer **19** may be formed of a single layer or multiple layers formed of an organic insulating layer. The third insulating layer **19** may include a typical polymer (e.g., poly(methyl)acrylate (PMMA) or polystyrene (PS)), a polymer derivative having a phenol group, an acrylic polymer, an imide-based polymer, an arylether-based

polymer, an amide-based polymer, a fluorine-based polymer, a p-xylene-based polymer, a vinyl alcohol-based polymer, or blends thereof.

[0069] A fourth insulating layer or pixel defining layer **20** is formed on a portion of the third insulating layer **19**. As will be described later, the fourth insulating layer **20** covers end portions of the pixel electrode **120** in the form of a closed loop and is formed on a portion of the third insulating layer **19**. The fourth insulating layer **20** may be formed of an organic insulating layer. The fourth insulating layer **20** may include a typical polymer (e.g., PMMA or PS), a polymer derivative having a phenol group, an acrylic polymer, an imide-based polymer, an arylether-based polymer, an amide-based polymer, a fluorine-based polymer, a p-xylene-based polymer, a vinyl alcohol-based polymer, or blends thereof.

[0070] The pixel area PXL1 includes the pixel electrode **120**, an opposite electrode **122** facing the pixel electrode **120**, and an intermediate layer **121** that includes an organic emitting layer **121a** and is formed between the pixel electrode **120** and the opposite electrode **122**.

[0071] The thin film transistor illustrated in FIG. 1 is a driving transistor that drives an OLED. Although a driving transistor is illustrated in FIG. 1, the OLED display **1** may further include a switching transistor (not shown) or a complementary transistor (not shown).

[0072] The structure of the thin film transistor as illustrated in FIG. 1 is one embodiment that may be employed in the OLED display **1** and the described technology is not limited to the structure of the thin film transistor illustrated in FIG. 1.

[0073] The pixel electrode **120** includes a semi-transmissive material. In detail, the pixel electrode **120** includes a semi-transmissive metal layer **120b**. A first transparent conductive oxide layer **120a** and a second transparent conductive oxide layer **120c** each including a transparent conductive oxide may be further respectively formed under and over the semi-transmissive metal layer **120b**.

[0074] The semi-transmissive metal layer **120b** may be formed of silver (Ag) or a Ag alloy. The semi-transmissive metal layer **120b** may form a micro-cavity structure with the opposite electrode **122** which is a reflective electrode to be described later, thereby improving the light efficiency of the OLED display **1**.

[0075] The first and second transparent conductive oxide layers **120a** and **120c** may include at least one material such as indium tin oxide (ITO), indium zinc oxide (IZO), zinc oxide (ZnO), indium oxide (In<sub>2</sub>O<sub>3</sub>), indium gallium oxide (IGO), or aluminum zinc oxide (AZO).

[0076] The first transparent conductive oxide layer **120a** formed under the semi-transmissive metal layer **120b** may reinforce the adhesive force between the pixel electrode **120** and the first insulating layer **13**.

[0077] The second transparent conductive oxide layer **120c** formed on the semi-transmissive metal layer **120b** may function as a barrier layer that protects the semi-transmissive metal layer **120b**.

[0078] When electrons produced during an etching operation for patterning the pixel electrode **120** reach a highly reducible metal such as Ag in the semi-transmissive metal layer **120b**, Ag ions included in an etchant may precipitate again as Ag. Ag that is precipitated in this manner may be the cause of particle defects that generate dark points in subsequent operations of forming the pixel electrode **120**.

[0079] If wirings such as a data wiring (not shown) or an electrode power supply wiring (not shown), which are formed

of the same materials as that of the source or drain electrodes **217a** or **217b**, or the source and drain electrodes **217a** and **217b** are exposed to an etchant, during the etching the pixel electrode **120**, electrons from these metals may be transferred to the highly reducible Ag ions included in the etchant. Consequently, the Ag ions may reprecipitate as Ag. For example, if these metals include Mo or Al, Mo provides Ag ions with electrons received from Al, thereby reprecipitating Ag. Ag particles that are reprecipitated may attach to the pixel electrode **120** in a subsequent operation and may cause particle pollution. This may result in defects such as dark point defects.

[0080] However, while the pixel electrode **120** is patterned, the OLED display **1** is protected by being covered by the third insulating layer **19** which is an organic layer to be described later. Accordingly, Ag particles that are reprecipitated during etching of the pixel electrode **120** are prevented from reattaching to the pixel electrode **120**, and thus, dark point defects may be substantially prevented.

[0081] An opening **C5** formed in the third insulating layer **19** is smaller than an opening **C1** formed in the second insulating layer **16**, and an opening **C9** formed in the fourth insulating layer **20** is larger than the opening **C5** formed in the third insulating layer **19**. The openings **C1**, **C5**, and **C9** overlap one another. Thus, the openings **C1**, **C5**, and **C9** are formed in similar areas so that the pixel electrode **120** may be located at positions where the openings **C1**, **C5**, and **C9** overlap.

[0082] The pixel electrode **120** is formed in an area where the opening **C1** formed in the second insulating layer **16** and the opening **C5** formed in the third insulating layer **19** overlap each other and the end portions of the pixel electrode **120** are formed outside of the opening **C5**. That is, the pixel electrode **120** extends over the third insulating layer **19**.

[0083] The opening **C9** that exposes an upper surface of the pixel electrode **120** is formed in the fourth insulating layer **20** and the fourth insulating layer **20** is formed to cover the end portions of the pixel electrode **120** to reduce the influence of an electrical field at the end portions of the pixel electrode **120**. A portion of the fourth insulating layer **20** that covers the end portions of the pixel electrode **120** is not formed within the opening **C5** formed in the third insulating layer **19** but only on a portion of the third insulating layer **19** outside the opening **C5**.

[0084] FIG. 3 is a schematic plan view illustrating the arrangement relationship between the pixel electrode **120** and the fourth insulating layer **20** in a plurality of pixels of the OLED display **1** according to an embodiment.

[0085] Referring to FIG. 3, the pixel electrode **120** is formed in the opening **C5** formed in the third insulating layer **19** (see FIG. 2) and the end portions of the pixel electrode **120** is formed on the third insulating layer **19**. The end portions of the pixel electrode **120** are surrounded by the fourth insulating layer **20** that functions as a pixel defining layer. The fourth insulating layer **20** is not formed entirely on the third insulating layer **19** but covers the end portions of the pixel electrode **120** in the form of a closed loop and may be formed only on a portion of the third insulating layer **19**. The fourth insulating layer **20** illustrated in FIG. 3 has a bar-shaped closed loop form; however, the described technology is not limited thereto.

[0086] The fourth insulating layer **20** which includes an organic insulating material has a relatively high absorption

coefficient, and thus, out gassing may occur, which may affect the lifetime of the OLED display during a manufacturing process thereof.

[0087] FIG. 4 is a graph showing the relationship between a standby exposure time and an absorption ratio of the fourth insulating layer **20** according to an embodiment. The horizontal axis denotes a time period during which the fourth insulating layer **20** is exposed to air and the vertical axis denotes a water absorption ratio. The fourth insulating layer **20** is formed of polyimide in the embodiment of FIG. 4.

[0088] Referring to FIG. 4, the fourth insulating layer **20** including polyimide maintains an absorption ratio of approximately 1% even after 10 minutes of exposure to air. If an amount of the fourth insulating layer **20** including moisture increases, the influence of out gassing may also increase.

[0089] However, according to the embodiment of FIGS. 2 and 3, the fourth insulating layer **20** is not formed entirely on the third insulating layer **19** but only in a portion outside the opening **C5** formed in the third insulating layer **19** on which the end portions of the pixel electrode **120** is formed. Thus, the amount of organic insulating material of which the fourth insulating layer **20** is formed may be reduced. Accordingly, the influence due to out gassing may be reduced.

[0090] FIG. 5 is a schematic cross-sectional view illustrating portions of a pixel and a pad unit of an OLED display **1C** according to a comparative example.

[0091] Referring to FIG. 5, a pixel area **PXL1C** including at least one organic emitting layer **121a**, a transistor area **TR1C** including at least one thin film transistor, a capacitor area **CAP1C** including at least one capacitor, and a pad area **PAD1C** are formed on a substrate **10** of the OLED display **1C** according to the comparative example.

[0092] In the OLED display **1** according to the above-described embodiment, the fourth insulating layer **20** is formed not entirely on the third insulating layer **19** but only on a portion of the third insulating layer **19** outside the opening **C5** where the end portions of the pixel electrode **120** are formed. However, in the OLED display **1C** according to the comparative example, the fourth insulating layer **20** is formed not only in the opening **C5** formed in the third insulating layer **19** but over the entire third insulating layer **19**. Compared to the above-described embodiment, the amount of the fourth insulating layer **20** is increased in the comparative example. Thus, the amount of out gassing due to the fourth insulating layer **20** is increased and the lifetime of the OLED display **1C** may be reduced accordingly.

[0093] The arrows illustrated on the fourth insulating layer **20** of FIG. 5 designate the movement direction of out gassing occurring in the fourth insulating layer **20**. As shown by the arrows, the out gassing occurring in the fourth insulating layer **20** diffuses from the fourth insulating layer **20** with time and may thereby affect the organic emitting layer **121a**.

[0094] Referring to FIG. 2, although a first pad layer **417** is located in an area exposed through a contact hole **C7** formed in the third insulating layer **19**, as a second pad layer **418** which is a protection layer is formed on the first pad layer **417**, the first pad layer **417** is not exposed to the etchant while the pixel electrode **120** is being etched. Thus, particle defects due to reprecipitation of Ag may be prevented.

[0095] An intermediate layer **121** including an organic emitting layer **121a** is formed between the pixel electrode **120** and the opposite electrode **122**. The intermediate layer **121** may include at least one of a hole injection layer (HIL), a hole transport layer, an electron transport layer, and an electron

injection layer, in addition to the organic emitting layer **121a**. However, the described technology is not limited thereto and the intermediate layer **121** may further include various other functional layers.

[0096] The OLED illustrated in FIG. 2 is an example of a sub-pixel that forms a unit pixel and the sub-pixel may emit light of various colors. For example, the sub-pixel may emit red, green or blue light.

[0097] Alternatively, the sub-pixel may emit white light. When a sub-pixel emits white light, the OLED display **1** may further include a color converting layer or a color filter that converts white light into colored light. A sub-pixel that emits white light may have various structures, and may have, for example, a structure in which a light-emitting material emitting at least red light, a light-emitting material emitting green light, and a light-emitting material emitting blue light are stacked.

[0098] Alternatively, a sub-pixel that emits white light may have a structure in which a light-emitting material emitting at least red light, a light-emitting material emitting green light, and a light-emitting material emitting blue light are mixed.

[0099] The red, green, and blue colors are just examples, and the described technology is not limited thereto. That is, as long as white light is emitted, any combination of other various colors besides the combination of red, green, and blue colors may also be used.

[0100] The opposite electrode **122** is located on the organic emitting layer **121a** as a common electrode formed commonly over all of the pixels. In the OLED display **1** according to FIGS. 2 and 3, the pixel electrode **120** is used as an anode electrode, and the opposite electrode **122** is used as a cathode electrode. The polarities of the electrodes may be obviously exchanged.

[0101] The opposite electrode **122** is a reflective electrode that includes a reflective material. The opposite electrode **122** may be formed of a single layer or multiple layers formed of at least one metal such as aluminum (Al), magnesium (Mg), nickel (Ni), calcium (Ca), or nickel fluoride (NiF).

[0102] A first light characteristics adjusting layer **1140** is formed between the pixel electrode **120** and the first insulating layer **13**.

[0103] The first light characteristics adjusting layer **1140** may include the same material as a second electrode **314** of the capacitor which will be described later and may include a transparent conductive oxide including indium tin oxide (ITO), indium zinc oxide (IZO), zinc oxide (ZnO), indium oxide ( $\text{In}_2\text{O}_3$ ), indium gallium oxide (IGO), or aluminum zinc oxide (AZO).

[0104] A semi-transmissive metal layer **120b** of the pixel electrode **120** including Ag may react with the material of the first insulating layer **13** located below the pixel electrode **120**. As the first transparent conductive oxide layer **120a** is formed below the semi-transmissive metal layer **120b** of the pixel electrode **120**, the thickness of the first transparent conductive oxide layer **120a** is relatively thin, and may be about 70 Å. Consequently, the first transparent conductive oxide layer **120a** may not be capable of completely protecting the pixel electrode **120b**.

[0105] For example, when the first insulating layer **13** which is used as a gate insulating layer has a double structure in which a silicon oxide layer and a silicon nitride layer are sequentially stacked in a direction from the buffer layer **11** toward the first light characteristics adjusting layer **1140**, the silicon nitride layer on the first insulating layer **13** is oxidized

due to various factors during a process and a silicon oxide layer is formed on a surface of the silicon nitride layer.

[0106] If the first light characteristics adjusting layer **1140** is not formed between the pixel electrode **120** and the first insulating layer **13**, Ag included in the semi-transmissive metal layer **120b** diffuses by reacting with the silicon oxide layer formed on the surface of the silicon nitride layer through a pin hole in the first transparent conductive oxide layer **120a** which is formed with a thin profile under the pixel electrode **120b**. Consequently, voids are formed in the semi-transmissive metal layer **120b**, and the diffused Ag results in dark point defects.

[0107] However, according to the embodiment of FIGS. 2 and 3, the first light characteristics adjusting layer **1140** is formed between the first insulating layer **13** and the pixel electrode **120**. Thus, even when a material that easily reacts with Ag is formed in the first insulating layer **13**, the first light characteristics adjusting layer **1140** may block diffusion of Ag. Thus, by controlling reactivity of Ag particles, dark point defects due to Ag particles may be remarkably prevented.

[0108] FIG. 6 illustrates the number of dark point defects of an OLED display before and after applying the first light characteristics adjusting layer **1140** under the same conditions.

[0109] Referring to FIG. 6, the average number of dark point defects before applying the first light characteristics adjusting layer **1140** was 86, but after the first light characteristics adjusting layer **1140** was applied, the average number of dark point defects was 17. The number of dark point defects has been significantly reduced.

[0110] Meanwhile, the first light characteristics adjusting layer **1140** according to the embodiment of FIGS. 2 and 3 not only reduces dark point defects but also improves the light efficiency of the OLED display **1**.

[0111] FIG. 7 is a graph showing the relationship between y color coordinates and the efficiency of a blue emitting layer.

[0112] In detail, the relationship between y color coordinates and the efficiency of a blue emitting layer is shown for the cases: ① a transparent protection layer is not included (standard example); ② the thickness of the transparent protection layer is about 150 Å; ③ the thickness of the transparent protection layer is about 300 Å; and the thickness of the transparent protection layer is about 370 Å. Here, ITO was used as a transparent conductive layer (in each case of ① through ④), ITO having a thickness of about 70 Å was used as a protection layer (the first transparent conductive oxide layer **120a**) under the semi-transmissive metal layer **120b**).

[0113] As can be seen from the graph of FIG. 7, as the thickness of ITO increases, the range of color coordinates that are selectable with respect to the standard example broadens and the efficiency increases. While not shown in the graph, if the thickness of ITO is about 800 Å or greater, the range of color coordinates is further narrowed, and the efficiency does not further increase. Thus, considering the function of preventing reactivity of Ag of the first light characteristics adjusting layer **1140** and improvement in light characteristics thereof, the first light characteristics adjusting layer **1140** may have a thickness in the range from about 200 Å to about 800 Å.

[0114] In the embodiment of FIG. 2, the first light characteristics adjusting layer **1140** extends to the thin film transistor area TR1 to contact a second contact layer **115a** that is formed of the same material as the gate electrode **215**. The second contact layer **115a** is electrically connected to one of

a source and drain electrode of a driving transistor via a contact hole C2 (see FIG. 8D) to thereby drive the pixel electrode 120.

[0115] If the pixel electrode 120 and a driving element are connected only via a contact hole C6 (see FIG. 8F) formed in the third insulating layer 19, step coverage may be poor as the pixel electrode 120 is used as a semi-transmissive metal layer and is relatively thin. Thus, a stable connection to an etching surface of the third insulating layer 19 or to the contact hole C6 may be difficult. However, according to the embodiment of FIG. 2, even if connection via the contact hole C6 formed in the third insulating layer 19 fails, the pixel electrode 120 may be connected to the second contact layer 115 via the first light characteristics adjusting layer 1140 in a bottom portion of the opening C5 and the second contact layer 115a may be connected to a driving element via a contact hole C2 (see FIG. 8D) formed in the second insulating layer 16. Accordingly, a signal from the driving element may be stably received.

[0116] In the capacitor area CAP1, a capacitor including a first electrode 312 formed in the same layer as the active layer 212, a second electrode 314 formed in the same layer as the gate electrode 215, and a third electrode 317 formed in the same layer as the source and drain electrodes 217a and 217b may be formed on the substrate 10 and the buffer layer 11.

[0117] The first electrode 312 of the capacitor may be formed of a semiconductor doped with ion impurities, like the source area 212a and the drain area 212b of the active layer 212.

[0118] Although the second electrode 314 of the capacitor is also formed on the first insulating layer 13 like the gate electrode 215, the second electrode 314 is formed of a different material. The material of the second electrode 314 may include a transparent conductive oxide. The capacitor having a metal-insulator-metal (MIM) structure may be formed by including the second electrode 314, which is a semiconductor doped with ion impurities.

[0119] The third electrode 317 of the capacitor may be formed of the same material as the source and drain electrodes 217a and 217b. As described above, as the third electrode 317 is covered by the third insulating layer 19 which is an organic layer, while the pixel electrode 120 including Ag is being etched, the third electrode 317 is not exposed to the etchant including Ag ions. Accordingly, particle defects due to reprecipitation of Ag may be prevented. Also, by connecting the capacitor parallel to the first electrode 312 and the second electrode 314, electrostatic capacitance of an OLED display may be increased without increasing the surface area of the capacitor. Accordingly, the surface area of the capacitor may be reduced by an increase in electrostatic capacitance, and accordingly, an aperture ratio may be increased.

[0120] An electrode protection layer 318 may be formed on the third electrode 317 of the capacitor. The third electrode 317 and the electrode protection layer 318 of the capacitor have the same etching surfaces because they are patterned in the same mask operation.

[0121] In an outer portion of the display area DA, a pad area PAD1 includes a pad electrode which is a connection terminal of an external driver.

[0122] The first pad layer 417 may include a plurality of metal layers having different electron mobilities, like the source and drain electrodes 217a and 217b. For example, the first pad layer 417 may be formed of a multi-layer formed of at least one metal selected from the group consisting of aluminum (Al), platinum (Pt), palladium (Pd), silver (Ag), mag-

nesium (Mg), gold (Au), nickel (Ni), neodymium (Nd), iridium (Ir), chromium (Cr), nickel (Li), calcium (Ca), molybdenum (Mo), titanium (Ti), tungsten (W), or copper (Cu).

[0123] The second pad layer 418 may be formed of a transparent conductive oxide that includes at least one material such as indium tin oxide (ITO), indium zinc oxide (IZO), zinc oxide (ZnO), indium oxide ( $\text{In}_2\text{O}_3$ ), indium gallium oxide (IGO), or aluminum zinc oxide (AZO). Accordingly, the first pad layer 417 may be prevented from being exposed to moisture and oxygen, thereby preventing a decrease in the reliability of the first pad layer 417 the pad area PAD1.

[0124] As described above, the first pad layer 417 may be formed in an area exposed through the contact hole C7 formed in the third insulating layer 19. However, since the second pad layer 418 which is a protection layer is formed on the first pad layer 417, the first pad layer 417 is not exposed to the etchant while the pixel electrode 120 is being etched.

[0125] Moreover, as an end portion of the first pad layer 417 that is sensitive to the external environment such as moisture or oxygen is covered by the third insulating layer 19, the end portion of the first pad layer 417 is also not exposed to the etchant during etching of the pixel electrode 120.

[0126] Consequently, particle defects due to reprecipitation of Ag may be prevented and a decrease in the reliability of the pad electrode may be prevented.

[0127] Although not illustrated in FIG. 2, the OLED display 1 may further include an encapsulation member (not shown) for encapsulating a display area including the pixel area PXL1, the capacitor area CAP1, and the thin film transistor area TR1. The encapsulation member may be formed of, for example, a substrate including a glass material, a metal film, or an encapsulation thin film formed by alternately disposing an organic insulating layer and an inorganic insulating layer.

[0128] FIGS. 8A through 8H are schematic cross-sectional views illustrating a method of manufacturing the OLED display 1, according to an embodiment.

[0129] FIG. 8A is a schematic cross-sectional view illustrating a first mask operation of the OLED display 1.

[0130] Referring to FIG. 8A, the buffer layer 11 is formed on the substrate 10 and a semiconductor layer (not shown) is formed on the buffer layer 11. The semiconductor layer (not shown) is patterned to form the active layer 212 and the first electrode 312 of the capacitor.

[0131] While not illustrated in FIG. 8A, the semiconductor layer (not shown) may be coated with a photoresist (not shown) and the semiconductor layer (not shown) may be patterned by using a photolithography method using a first photomask (not shown), thereby forming the active layer 212 and the first electrode 312 described above. The first mask operation using a photolithography method is performed by exposing the first photomask (not shown) by using exposure equipment and then performing a series of processes such as developing, etching, and stripping or ashing.

[0132] The semiconductor layer may be formed of amorphous silicon or crystalline polysilicon. The crystalline polysilicon may be formed by crystallizing amorphous silicon. Example methods for crystallizing amorphous silicon include rapid thermal annealing (RTA), solid phase crystallization (SPC), excimer laser annealing (ELA), metal induced crystallization (MIC), or metal induced lateral crystallization

(MILC). The semiconductor layer (not shown) is not limited to amorphous or crystalline silicon and may include an oxide semiconductor.

[0133] FIG. 8B is a schematic cross-sectional view illustrating a second mask operation of the OLED display 1.

[0134] The first insulating layer 13 is formed on the resultant product of the first mask operation and a first metal layer (not shown) is formed on the first insulating layer 13 and patterned.

[0135] The first metal layer (not shown) may be formed of a single layer or multiple layers formed of at least one metal such as aluminum (Al), platinum (Pt), palladium (Pd), silver (Ag), magnesium (Mg), gold (Au), nickel (Ni), neodymium (Nd), iridium (Ir), chromium (Cr), nickel (Li), calcium (Ca), molybdenum (Mo), titanium (Ti), tungsten (W), or copper (Cu). As a result of the patterning, the second contact layer 115a of a pixel electrode contact portion and the gate electrode 215 are formed on the first insulating layer 13.

[0136] FIG. 8C is a schematic cross-sectional view illustrating a third mask operation of the OLED display 1.

[0137] A transparent conductive oxide layer (not shown) is stacked on the resultant product of the second mask operation of FIG. 8B and patterned. As a result of the patterning, the first light characteristics adjusting layer 1140 and the second electrode 314 of the capacitor are formed.

[0138] The structure formed as described above may be doped with ion impurities. The ion impurities may be boron (B) or phosphorus (P) ions and the structure may be doped with a density of about  $1 \times 10^{15}$  atoms/cm<sup>2</sup> or greater by using the active layer 212 of the thin film transistor and the first electrode 312 of the capacitor as a target.

[0139] By doping the active layer 212 with ion impurities using the gate electrode 215 as a self-align mask, the active layer 212 includes the source area 212a, the drain area 212b, and the channel area 212c doped with ion impurities. The channel area 212c is positioned between the source and drain areas 212a and 212b. The first electrode 312 of the capacitor may also be doped with ion impurities to form an electrode that forms a MIM CAP structure.

[0140] Accordingly, the active layer 212 and the first electrode 312 of the capacitor are doped in a single doping operation, thereby reducing the manufacturing costs by reduction in the number of doping processes.

[0141] FIG. 8D is a schematic cross-sectional view illustrating the result of a fourth mask operation of the OLED display 1.

[0142] Referring to FIG. 8D, the second insulating layer 16 is formed on the resultant product of the third mask operation of FIG. 8C and the second insulating layer 16 is patterned to form openings C3 and C4 that expose the source and drain areas 212a and 212b of the active layer 212, an opening C2 that exposes the second contact layer 115a, and an opening C1 in an area separated from the active layer 212 where the pixel electrode 120 which will be described later is to be formed.

[0143] FIG. 8E is a schematic cross-sectional view illustrating the result of a fifth mask operation of the OLED display 1.

[0144] Referring to FIG. 8E, a second metal layer (not shown) and a protection layer (not shown) are continuously formed on the resultant product of the fourth mask operation. The second metal layer (not shown) and the protection layer (not shown) are simultaneously patterned, thereby forming the source and drain electrodes 217a and 217b, the wiring

protection layers 218a and 218b, the third electrode 317 and the electrode protection layer 318 of the capacitor, and the first pad layer 417 and the second pad layer 418 of the pad electrode in a single mask operation.

[0145] The second metal layer (not shown) may be formed of at least two heterogeneous metal layers having different electron mobilities. For example, the second metal layer (not shown) may be formed of at least two metal layers such as aluminum (Al), platinum (Pt), palladium (Pd), silver (Ag), magnesium (Mg), gold (Au), nickel (Ni), neodymium (Nd), iridium (Ir), chromium (Cr), nickel (Li), calcium (Ca), molybdenum (Mo), titanium (Ti), tungsten (W), copper (Cu), or alloys thereof.

[0146] To illustrate the structure of the second metal layer (not shown), the structure of the first pad layer 417 is illustrated in detail. In some embodiments, the second metal layer (not shown) is formed of a first layer 417a including Mo, a second layer 417b including Al, and a third layer 417c including Mo.

[0147] The second layer 417b including Al may be a metal layer having a low resistance and excellent electrical characteristics and the first layer 417a that is formed below the second layer 417b and includes Mo increases the adhesive force with respect to the second insulating layer 16, and the third layer 417c that is formed on the second layer 417b and includes Mo functions as a barrier layer that prevents hillocks, oxidation, and diffusion of Al included in the second layer 417b.

[0148] The protection layer (not shown) may include a transparent conductive oxide.

[0149] Meanwhile, while not illustrated in the drawings in detail, the second metal layer (not shown) may be patterned in the fifth mask operation to also form data wirings.

[0150] FIG. 8F is a schematic cross-sectional view illustrating the resultant product of a sixth mask operation of the OLED display 1.

[0151] Referring to FIG. 8F, a third insulating layer 19 is formed on the resultant product of the fifth mask operation and the third insulating layer 19 is patterned to form contact holes C7 and C6 that expose upper portions of the second pad layer 418 and the wiring protection layer 218b and an opening C5 in the pixel area PXL1 in which the pixel electrode 120 to be described later is to be formed.

[0152] The third insulating layer 19 is formed to completely surround the source and drain electrodes 217a and 217b so as to prevent contact of heterogeneous wirings having different potentials to the etchant including Ag ions during etching of the pixel electrode 120.

[0153] The opening C5 formed in the third insulating layer 19 and the opening C1 formed in the second insulating layer 16 are formed to overlap and the opening C5 is formed to be smaller than the opening C1.

[0154] FIG. 8G is a schematic cross-sectional view illustrating the result of a seventh mask operation of the OLED display 1.

[0155] Referring to FIG. 8G, a semi-transmissive metal layer (not shown) is formed on the resultant product of the sixth mask operation of FIG. 8F and the semi-transmissive metal layer (not shown) is patterned to form the pixel electrode 120.

[0156] The pixel electrode 120 is formed in an area where the opening C1 formed in the second insulating layer 16 and the opening C5 formed in the third insulating layer 19 overlap each other and an end portion of the pixel electrode 120 is

formed outside of the opening C5. That is, the end portion of the pixel electrode 120 extends over the third insulating layer 19.

[0157] The pixel electrode 120 is formed of a semi-transmissive metal layer 120b. Also, the pixel electrode 120 may further include first and second transparent conductive oxide layers 120a and 120c that are formed under and on the semi-transmissive metal layer 120b and protect the semi-transmissive metal layer 120b.

[0158] The semi-transmissive metal layer 120b may be formed of Ag or an Ag alloy. The first and second transparent conductive oxide layers 120a and 120c that include a transparent conductive oxide may include at least one material such as indium tin oxide (ITO), indium zinc oxide (IZO), zinc oxide (ZnO), indium oxide ( $\text{In}_2\text{O}_3$ ), indium gallium oxide (IGO), or aluminum zinc oxide (AZO). The semi-transmissive metal layer 120b may form a micro-cavity structure with the opposite electrode 122 which is a reflective electrode to be described later and may increase the light efficiency of the OLED display 1.

[0159] When electrons are provided to a highly reducible metal such as Ag during an etching operation for patterning the pixel electrode 120, Ag ions included in the etchant may precipitate as Ag. If the source electrode 217a, the drain electrode 217b, the first contact layer 117 of the pixel electrode contact portion, the first pad layer 417, or data wirings (not shown) are exposed to the etchant during etching of the pixel electrode 120 including Ag, electrons from these metals may reach the Ag ions that are highly reducible and the Ag ions may reprecipitate as Ag.

[0160] However, the source and drain electrodes 217a and 217b according to the embodiment of FIG. 8 are patterned prior to the operation of patterning the pixel electrode 120 and are covered by the third insulating layer 19 which is an organic layer. Thus, during etching of the pixel electrode 120 including Ag, the source and drain electrodes 217a and 217b are not exposed to the etchant. Accordingly, particle defects due to reprecipitation of Ag may be prevented.

[0161] In addition, while the first pad layer 417 is formed in an area exposed through the contact hole C7 formed in the third insulating layer 19, since the second pad layer 418 which is a protection layer is formed on the first pad layer 417, the first pad layer 417 is not exposed to the etchant while the pixel electrode 120 is being etched. Accordingly, particle defects due to reprecipitation of Ag may be prevented.

[0162] If the first light characteristics adjusting layer 1140 is not formed between the pixel electrode 120 and the first insulating layer 13, Ag included in the semi-transmissive metal layer 120b may diffuse by reacting with a silicon oxide layer formed on the surface of the silicon nitride layer through a pin hole in the first transparent conductive oxide layer 120a which has a thin profile and is formed below the pixel electrode 120b. Consequently, voids may be formed in the pixel electrode 120b and the diffused Ag may cause dark point defects.

[0163] However, according to the embodiment of FIG. 8, since the first light characteristics adjusting layer 1140 is formed between the first insulating layer 13 and the pixel electrode 120, even when a material that easily reacts with Ag is formed on the first insulating layer 13, the first light characteristics adjusting layer 1140 may block diffusion of Ag. Thus, by controlling reactivity of Ag particles, dark point defects due to the Ag particles may be remarkably prevented.

[0164] FIG. 8H is a schematic cross-sectional view illustrating the result of an eighth mask operation of the OLED display 1.

[0165] Referring to FIG. 8H, a fourth insulating layer 20 is formed on the resultant product of the seventh mask operation of FIG. 8G and then the eighth mask operation of forming an opening C9 exposing an upper portion of the pixel electrode 120 is performed.

[0166] The opening C9 that exposes the upper surface of the pixel electrode 120 is formed in the fourth insulating layer 20 and the fourth insulating layer 20 is formed to cover the end portions of the pixel electrode 120 to reduce the influence of an electrical field at the end portion of the pixel electrode 120. The portion of the fourth insulating layer 20 that covers the end portions of the pixel electrode 120 is not formed in the opening C5 formed in the third insulating layer 19 but only on the third insulating layer 19 outside of the opening C5.

[0167] The fourth insulating layer 20 may be formed of an organic insulating layer such as a typical polymer (e.g., PMMA or PS), a polymer derivative having a phenol group, an acrylic polymer, an imide-based polymer, an arylether-based polymer, an amide-based polymer, a fluorine-based polymer, a p-xylene-based polymer, or a vinyl alcohol-based polymer.

[0168] The fourth insulating layer 20 which includes an organic insulating material has a high absorption coefficient, and thus, out gassing which may affect the lifetime of an OLED display may occur during a manufacturing process. However, according to the embodiment of FIG. 2, the fourth insulating layer 20 is not formed entirely on the third insulating layer 19 but only on a portion of the upper surface of the third insulating layer 19 outside of the opening C5 where the end portions of the pixel electrode 120 are formed. Thus, the amount of the organic insulating material required to form the fourth insulating layer 20 is reduced. Accordingly, the influence due to out gassing may be reduced.

[0169] The intermediate layer 121 including the organic emitting layer 121a (see FIG. 2) and the opposite electrode 122 (see FIG. 2) are formed on the resultant product of the eighth mask operation of FIG. 8H.

[0170] According to at least one embodiment, the pixel electrode 120 is formed to include the semi-transmissive metal layer 120b, thereby improving the light efficiency of the OLED display 1 due to a micro-cavity.

[0171] Also, by covering the source and drain electrodes 217a and 217b with the third insulating layer 19 which is an organic layer, the source and drain electrodes 217a and 217b are not exposed to an etchant containing Ag ions, thereby preventing particle defects due to reprecipitation of Ag.

[0172] Also, by forming the second pad layer 418, which is a protection layer, on the first pad layer 417, and a wiring protection layer 218b, which is a protection layer, on the drain electrode 217b, the first pad layer 417 and the drain electrode 217b are not exposed to the etchant while the pixel electrode 120 is being etched, thereby preventing particle defects due to reprecipitation of Ag.

[0173] Also, as the first light characteristics adjusting layer 1140 is formed under the pixel electrode 120, even when the first insulating layer 13 is formed of a material that easily reacts with Ag, the first light characteristics adjusting layer 1140 blocks diffusion of Ag to thereby remove reactivity of Ag particles, so that dark point defects may be remarkably reduced and light characteristics may be improved.

[0174] Also, as the fourth insulating layer 20 that covers the end portions of the pixel electrode 120 is not entirely formed on the third insulating layer 19 but only on a portion of an upper portion of the third insulating layer 19. Thus, the amount of organic insulating material from which the fourth insulating layer 20 is formed may be reduced. Consequently, the influence due to out gassing may be reduced, thereby improving the lifetime of the OLED display 1.

[0175] Hereinafter, an OLED display 2 according to another embodiment will be described.

[0176] FIG. 9 is a schematic cross-sectional view illustrating portions of a pixel and a pad unit of the OLED display 2.

[0177] Referring to FIG. 9, a pixel area PXL2 including at least one organic emitting layer 121a, a transistor area TR2 including at least one thin film transistor, a capacitor area CAP2 including at least one capacitor, and a pad area PAD2 are formed on a substrate 10 of the OLED display 2.

[0178] The OLED display 2 may include all of the components of the OLED display 1 described in connection with the embodiment of FIG. 2.

[0179] For example, the OLED display 2 may include the pixel electrode 120 formed of the semi-transmissive metal layer 120b, thereby increasing the light efficiency of the OLED display 2 due to a micro-cavity.

[0180] Also, by covering the source and drain electrodes 217a and 217b with the third insulating layer 19, which is an organic layer, the source and drain electrodes 217a and 217b are not exposed to an etchant containing Ag ions, thereby preventing particle defects due to reprecipitation of Ag.

[0181] Also, by forming the second pad layer 418, which is a protection layer, on the first pad layer 417 and a wiring protection layer 218b, which is a protection layer, on the drain electrode 217b, the first pad layer 417 and the drain electrode 217b are not exposed to an etchant while the pixel electrode 120 is being etched, thereby preventing particle defects due to reprecipitation of Ag.

[0182] Also, since a second light characteristics adjusting layer 1180 is formed under the pixel electrode 120, even when the first insulating layer 13 is formed of a material that easily reacts with Ag, the second light characteristics adjusting layer 1180 blocks diffusion of Ag to thereby prevent the reactivity of Ag particles, so that dark points defects may be remarkably reduced and light characteristics may be improved.

[0183] Also, as the fourth insulating layer 20 that covers the end portions of the pixel electrode 120 is not entirely formed on the third insulating layer 19 but only on a portion of an upper portion of the third insulating layer 19, the amount of organic insulating material required to form the fourth insulating layer 20 may be reduced. Consequently, the influence due to out gassing may be reduced, thereby improving the lifetime of the OLED display 2.

[0184] While the first light characteristics adjusting layer 1140 (see FIG. 2) is formed of the same material as the second electrode 314 of the capacitor in the above-described embodiment, the second light characteristics adjusting layer 1180 may be formed of the same material as the second pad layer 418. Thus, in the embodiment of FIG. 9, the second light characteristics adjusting layer 1180 may include a transparent conductive oxide including indium tin oxide (ITO), indium zinc oxide (IZO), zinc oxide (ZnO), indium oxide (In<sub>2</sub>O<sub>3</sub>), indium gallium oxide (IGO), or aluminum zinc oxide (AZO).

[0185] A pixel electrode contact portion includes a first contact layer 114 formed of a transparent conductive oxide and a second contact layer 115a formed of the same material

as the gate electrode 215. An end portion of the first contact layer 114 protrudes from etching surfaces of the opening C1 formed in the second insulating layer 16 and the opening C5 formed in the third insulating layer 19. Accordingly, the pixel electrode 120 is electrically connected to the first contact layer 114 through the second light characteristics adjusting layer 1180 and the first contact layer 114 may contact the second contact layer 115a.

[0186] Hereinafter, a method of manufacturing the OLED display 2 will be described with reference to FIGS. 10A through 10I.

[0187] FIG. 10A is a schematic cross-sectional view illustrating a first mask operation of the OLED display 2.

[0188] Referring to FIG. 10A, the buffer layer 11 is formed on the substrate 10 and the semiconductor layer (not shown) is formed on the buffer layer 11. The active layer 212 of the thin film transistor and the first electrode 312 of the capacitor are formed by patterning the semiconductor layer (not shown).

[0189] FIG. 10B is a schematic cross-sectional view illustrating a second mask operation of the OLED display 2.

[0190] The first insulating layer 13 is formed on the resultant product of the first operation of FIG. 10A and a transparent conductive oxide layer (not shown) is formed on the first insulating layer 13 and is patterned.

[0191] As a result of patterning, the first contact layer 114 and the second electrode 314 of the capacitor are formed on the first insulating layer 13.

[0192] FIG. 10C is a schematic cross-sectional view of a third mask operation of the OLED display 2.

[0193] A first metal layer (not shown) is stacked on the resultant product of the second mask operation of FIG. 10B and the stacked structure is patterned. As described above, the first metal layer (not shown) may be formed of a single layer or multiple layers formed of at least one metal such as aluminum (Al), platinum (Pt), palladium (Pd), silver (Ag), magnesium (Mg), gold (Au), nickel (Ni), neodymium (Nd), iridium (Ir), chromium (Cr), nickel (Li), calcium (Ca), molybdenum (Mo), titanium (Ti), tungsten (W), or copper (Cu).

[0194] As a result of the patterning, the gate electrode 215 and the gate metal layer 115 covering the first contact layer 114 are formed on the first insulating layer 13.

[0195] The structure described above is doped with ion impurities. The ion impurities may be B or P ions and the structure may be doped at a density of about  $1 \times 10^{15}$  atoms/cm<sup>2</sup> or greater by using the active layer 212 and the first electrode 312 of the capacitor as a target.

[0196] The active layer 212 may be doped with ion impurities by using the gate electrode 215 as a self-align mask. As a result, the active layer 212 has the source area 212a and the drain area 212b, which are doped with ion impurities, and the channel area 212c therebetween. The first electrode 312 of the capacitor may also be doped with ion impurities to function as an electrode that forms a MIM CAP structure.

[0197] Accordingly, the active layer 212 and the first electrode 312 of the capacitor may be doped simultaneously in a single doping operation, thereby reducing the manufacturing costs due to reduction in doping operations.

[0198] FIG. 10D is a schematic cross-sectional view illustrating the result of the fourth mask operation of the OLED display 2.

[0199] Referring to FIG. 10D, the second insulating layer 16 is formed on the resultant product of the third mask operation of FIG. 10C and the second insulating layer 16 is patterned to form the openings C3 and C4 that expose the source

and drain areas **212a** and **212b** of the active layer **212**, the opening **C2** that exposes a portion of the gate metal layer **115**, and the opening **C1** in an area separated from the active layer **212** as an area where the pixel electrode **120** to be described later is to be formed.

[0200] FIG. 10E is a schematic cross-sectional view illustrating the result of a fifth mask operation of the OLED display **2**.

[0201] Referring to FIG. 10E, a second metal layer (not shown) is formed on the resultant product of the fourth mask operation of FIG. 10D and the second metal layer (not shown) is patterned, thereby forming the source and drain electrodes **217a** and **217b**, the third electrode **317** of the capacitor, and the first pad layer **417** of the pad electrode at the same time.

[0202] The second metal layer (not shown) may be formed of at least two heterogeneous metal layers having different electron mobilities. For example, the second metal layer (not shown) may be formed of at least two metal layers such as aluminum (Al), platinum (Pt), palladium (Pd), silver (Ag), magnesium (Mg), gold (Au), nickel (Ni), neodymium (Nd), iridium (Ir), chromium (Cr), nickel (Li), calcium (Ca), molybdenum (Mo), titanium (Ti), tungsten (W), copper (Cu), or alloys thereof.

[0203] To illustrate the structure of the second metal layer (not shown), the structure of the first pad layer **417** is illustrated in detail in FIG. 10F. In some embodiments, the second metal layer (not shown) is formed of the first layer **417a** including Mo, the second layer **417b** including Al, and the third layer **417c** including Mo.

[0204] The second layer **417b** including Al may be a metal layer having a low resistance and excellent electrical characteristics and the first layer **417a** that is formed below the second layer **417b** and includes Mo increases the adhesive force with respect to the second insulating layers **16**. The third layer **417c** that is formed on the second layer **417b** and includes Mo may function as a barrier layer that prevents hillocks, oxidation, and diffusion of Al included in the second layer **417b**.

[0205] Furthermore, while not illustrated in the drawings in detail, the second metal layer (not shown) may be patterned in the fifth mask operation to also form a data wiring.

[0206] FIG. 10F is a schematic cross-sectional view illustrating the result of the sixth mask operation of the OLED display **2**.

[0207] Referring to FIG. 10F, the second pad layer **418** and the second light characteristics adjusting layer **1180** are formed on the resultant product of the fifth mask operation of FIG. 10E.

[0208] FIG. 10G is a schematic cross-sectional view illustrating the result of a seventh mask operation of the OLED display **2**.

[0209] Referring to FIG. 10G, the third insulating layer **19** is formed on the resultant product of the fifth mask operation and the third insulating layer **19** is patterned to form the contact hole **C7** that exposes an upper portion of the second pad layer **418** and the opening **C5** in the pixel area **PXL2** in which the pixel electrode **120** to be described later is to be formed.

[0210] The third insulating layer **19** is formed to completely surround the source and drain electrodes **217a** and **217b** so as to prevent contact of heterogeneous wirings having different potential differences during the etching of the pixel electrode **120** including Ag, which will be described later, to an etchant including Ag ions.

[0211] The opening **C5** formed in the third insulating layer **19** and the opening **C2** formed in the second insulating layer **16** overlap and the opening **C5** formed in the third insulating layer **19** is smaller than the opening **C1** formed in the second insulating layer **16**.

[0212] FIG. 10H is a schematic cross-sectional view illustrating the result of an eighth mask operation of the OLED display **2**.

[0213] Referring to FIG. 10H, a semi-transmissive metal layer (not shown) is formed on the resultant product of the seventh mask operation of FIG. 10G and the semi-transmissive metal layer (not shown) is patterned to form the pixel electrode **120**.

[0214] The pixel electrode **120** is formed in an area where the opening **C1** formed in the second insulating layer **16** and the opening **C5** formed in the third insulating layer **19** overlap each other and end portions of the pixel electrode **120** are formed outside of the opening **C5** formed in the third insulating layer **19**. That is, the end portions of the pixel electrode **120** extend over the third insulating layer **19**.

[0215] The pixel electrode **120** is formed of the semi-transmissive metal layer **120b**. Also, the pixel electrode **120** may further include the first and second transparent conductive oxide layers **120a** and **120c** that are formed under and on the semi-transmissive metal layer **120b** and protect the semi-transmissive metal layer **120b**.

[0216] FIG. 10I is a schematic cross-sectional view illustrating the result of a ninth mask operation of the OLED display **2**.

[0217] Referring to FIG. 10I, the fourth insulating layer **20** is formed on the resultant product of the eighth mask operation and the ninth mask operation of forming an opening **C8** that exposes an upper portion of the pixel electrode **120** is performed.

[0218] The opening **C9** that exposes an upper surface of the pixel electrode **120** is formed in the fourth insulating layer **20** and the fourth insulating layer **20** is formed to cover the end portions of the pixel electrode **120** to reduce an influence of an electrical field at the end portions of the pixel electrode **120**. A portion of the fourth insulating layer **20** that covers the end portions of the pixel electrode **120** is not formed within the opening **C5** formed in the third insulating layer **19** but only on a portion of the third insulating layer **19** outside of the opening **C5**. As the fourth insulating layer **20** is not entirely formed on the third insulating layer **19** but only on a portion of an upper portion of the third insulating layer **19** outside the opening **C5**, the amount of organic insulating material, from which the fourth insulating layer **20** is formed, may be reduced. Accordingly, the influence due to out gassing may be reduced.

[0219] The intermediate layer **121** including the organic emitting layer **121a** (see FIG. 9) and the opposite electrode **122** (see FIG. 9) are formed on the resultant product of the ninth mask operation of FIG. 10I.

[0220] According to at least one embodiment, the pixel electrode **120** is formed of the semi-transmissive metal layer **120b**, thereby improving the light efficiency of the OLED display **2** due to a micro-cavity.

[0221] Also, by covering the source and drain electrodes **217a** and **217b** with the third insulating layer **19**, which is an organic layer, the source and drain electrodes **217a** and **217b** are not exposed to an etchant containing Ag ions, thereby preventing particle defects due to reprecipitation of Ag.

[0222] Also, by forming the second pad layer **418**, which is a protection layer, on the first pad layer **417** and the wiring protection layer **218b**, which is a protection layer, on the drain electrode **217b**, the first pad layer **417** and the drain electrode **217b** are not exposed to the etchant while the pixel electrode **120** is being etched, thereby preventing particle defects due to reprecipitation of Ag.

[0223] Also, since the second light characteristics adjusting layer **1180** is formed under the pixel electrode **120**, even when the first insulating layer **13** is formed of a material that easily reacts with Ag, the second light characteristics adjusting layer **1180** blocks diffusion of Ag to thereby remove reactivity of Ag particles, so that dark points defects may be remarkably reduced and light characteristics of the OLED display **2** may be improved.

[0224] Also, as the fourth insulating layer **20** that covers the end portions of the pixel electrode **120** is not entirely formed on the third insulating layer **19** but only on a portion of an upper portion of the third insulating layer **19**, the amount of organic insulating material, from which the fourth insulating layer **20** is formed, may be reduced. Consequently, the influence due to out gassing may be reduced, thereby improving the lifetime of the OLED display **2**.

[0225] As described above, according to at least one embodiment, the OLED display has a high light efficiency, a high yield, and an improved display quality.

[0226] It should be understood that the exemplary embodiments described herein should be considered in a descriptive sense only and not for purposes of limitation. Descriptions of features or aspects within each embodiment should typically be considered as available for other similar features or aspects in other embodiments.

[0227] While one or more embodiments have been described with reference to the figures, it will be understood by those of ordinary skill in the art that various changes in form and details may be made therein without departing from the spirit and scope of the present invention as defined by the following claims.

What is claimed is:

1. An organic light-emitting diode (OLED) display, comprising:

a thin film transistor comprising an active layer, a gate electrode, a source electrode, and a drain electrode;

a first insulating layer formed at least between the active layer and the gate electrode;

a second insulating layer formed at least between the gate electrode and the source and drain electrodes;

a third insulating layer covering the source and drain electrodes;

a pixel electrode comprising i) a first portion formed in first and second openings respectively defined in the second and third insulating layers and ii) a second portion formed outside of the second opening;

a pixel defining layer formed over the second portion of the pixel electrode and the third insulating layer, wherein a third opening is formed in the pixel defining layer;

an intermediate layer formed over the pixel electrode and including an organic emitting layer; and

an opposite electrode formed over the intermediate layer, wherein the third opening has an area greater than that of the second opening.

2. The OLED display of claim 1, wherein the third insulating layer is formed at least in part of an organic material.

3. The OLED display of claim 1, wherein the pixel defining layer is formed at least in part of an organic material.

4. The OLED display of claim 1, wherein the pixel defining layer covers has a closed loop shape.

5. The OLED display of claim 1, wherein the pixel electrode includes a semi-transmissive metal layer and wherein the opposite electrode includes a reflection layer.

6. The OLED display of claim 5, wherein the semi-transmissive metal layer is formed at least in part of silver or a silver alloy.

7. The OLED display of claim 5, further comprising a transparent conductive oxide layer formed at least between the semi-transmissive metal layer and the first insulating layer.

8. The OLED display of claim 1, further comprising a light characteristics adjusting layer formed at least between the first insulating layer and the pixel electrode.

9. The OLED display of claim 8, wherein the light characteristics adjusting layer has a thickness of about 200 Å to about 800 Å.

10. The OLED display of claim 8, wherein the light characteristics adjusting layer is formed at least in part of a transparent conductive oxide material.

11. The OLED display of claim 1, wherein the second portion of the pixel electrode is electrically connected to one of the source and drain electrodes via a contact hole formed in the third insulating layer.

12. The OLED display of claim 1, further comprising a contact layer formed between the first and second insulating layers, wherein the pixel electrode is electrically connected to one of the source and drain electrodes via the contact layer.

13. The OLED display of claim 1, wherein the source and drain electrodes are each formed of a plurality of heterogeneous metal layers having different electron mobilities.

14. The OLED display of claim 13, wherein the source and drain electrodes each comprise a layer including molybdenum (Mo) and a layer including aluminum (Al).

15. The OLED display of claim 1, further comprising a wiring protection layer formed over the source and drain electrodes.

16. The OLED display of claim 15, wherein etching surfaces of the source and drain electrodes and the wiring protection layer are the same.

17. The OLED display of claim 1, further comprising a capacitor including a first electrode formed in the same layer as the active layer and a second electrode formed in the same layer as the gate electrode.

18. The OLED display of claim 17, wherein the first electrode of the capacitor is formed at least in part of a semiconductor material doped with ion impurities.

19. The OLED display of claim 17, wherein the second electrode of the capacitor is formed at least in part of a transparent conductive oxide material.

20. The OLED display of claim 17, further comprising a light characteristics adjusting layer formed at least between the first insulating layer and the pixel electrode, wherein the second electrode of the capacitor is formed of the same material as the light characteristics adjusting layer.

21. The OLED display of claim 1, further comprising:

a first pad layer formed of the same material as the source and drain electrodes; and

a second pad layer formed over the first pad layer.

22. The OLED display of claim 21, further comprising a light characteristics adjusting layer formed at least between

the first insulating layer and the pixel electrode, wherein the second pad layer is formed of the same material as the light characteristics adjusting layer.

**23.** The OLED display of claim **1**, wherein the first and second openings and the third opening formed in the pixel defining layer substantially overlap each other.

**24.** An organic light-emitting diode (OLED) display, comprising:

a substrate;

an insulating layer formed over the substrate and defining a plurality of openings;

a plurality of pixels formed over the substrate and respectively corresponding to the openings, each of the pixels comprising:

a pixel electrode comprising i) a first portion formed in the corresponding opening and ii) a second portion formed over the insulating layer and not forming in the opening; and

a pixel defining layer formed over the second portion of the pixel electrode and the insulating layer,

wherein each of the pixel defining layers has a closed loop shape, and

wherein each of the pixel defining layers is spaced apart from adjacent pixel defining layers.

**25.** The OLED display of claim **24**, wherein each of the pixel defining layers is not formed in the corresponding opening.

**26.** The OLED display of claim **24**, wherein the length of the first portion of the pixel electrode is greater than that of the second portion of the pixel electrode.

**27.** The OLED display of claim **24**, wherein the second portion comprises a peripheral portion of the pixel electrode.

\* \* \* \* \*

专利名称(译)	有机发光二极管 ( OLED ) 显示器		
公开(公告)号	<a href="#">US20150115256A1</a>	公开(公告)日	2015-04-30
申请号	US14/525009	申请日	2014-10-27
[标]申请(专利权)人(译)	三星显示有限公司		
申请(专利权)人(译)	三星DISPLAY CO. , LTD.		
当前申请(专利权)人(译)	三星DISPLAY CO. , LTD.		
[标]发明人	YOU CHUN GI		
发明人	YOU, CHUN-GI		
IPC分类号	H01L27/32 H01L29/45 H01L49/02 H01L51/52		
CPC分类号	H01L27/3265 H01L27/3246 H01L51/5215 H01L28/60 H01L51/5271 H01L29/45 H01L27/3262 H01L51/5221 H01L27/1225 H01L27/124 H01L27/1255 H01L27/3258 H01L27/3248 H01L27/3279 H01L51/5231 H01L2251/305 H01L2251/558		
优先权	1020130130450 2013-10-30 KR		
其他公开文献	US9373671		
外部链接	<a href="#">Espacenet</a> <a href="#">USPTO</a>		

摘要(译)

公开了一种有机发光二极管 ( OLED ) 显示器。在一个方面, OLED显示器包括薄膜晶体管, 该薄膜晶体管包括有源层, 栅电极, 源电极和漏电极。至少在有源层和栅电极之间形成第一绝缘层, 并且至少在栅电极, 源电极和漏电极之间形成第二绝缘层。OLED显示器还包括覆盖源电极和漏电极的第三绝缘层和像素电极, 像素电极包括形成在分别限定在第二和第三绝缘层中的第一和第二开口中的第一部分和形成在第二开口外部的第二部分。像素限定层形成在像素电极和第三绝缘层的第二部分上方并具有第三开口。第三开口的面积大于第二开口的面积。

